

TESTING AND COMMISSIONING PROCEDURE

FOR

AIR-CONDITIONING, REFRIGERATION, VENTILATION

AND

CENTRAL MONITORING & CONTROL SYSTEM

INSTALLATION

IN

GOVERNMENT BUILDINGS

OF

THE HONG KONG SPECIAL ADMINISTRATIVE REGION

2017 EDITION



ARCHITECTURAL SERVICES DEPARTMENT
THE GOVERNMENT OF THE HONG KONG SPECIAL ADMINISTRATIVE REGION

PREFACE

This Testing and Commissioning (T&C) Procedure aims to lay down the minimum testing and commissioning requirements to be carried out on Air-conditioning, Refrigeration, Ventilation and Central Monitoring and Control System Installation in Government Buildings of the Hong Kong Special Administrative Region (HKSAR). Such requirements are applicable to both new installations upon completion and existing ones after major alteration.

The 2017 edition was developed from the 2012 edition by the Air-conditioning Specialist Support Group that was established under the Building Services Branch Technical Information and Research & Development Committee of the Architectural Services Department (ArchSD). This T&C Procedure has incorporated the latest changes in the 2017 edition of the General Specification for Air-conditioning, Refrigeration, Ventilation and Central Monitoring and Control System Installation.

With the benefit of information technology, electronic version of this T&C procedure is to be viewed on and free for download from the ArchSD Internet homepage. As part of the Government's efforts to limit paper consumption, hard copies of this T&C Procedure will not be put up for sale.

The ArchSD welcomes comments on this T&C Procedure at any time since the updating of this T&C Procedure is a continuous process to tie in with technological advances.

DISCLAIMER

This T&C Procedure is solely compiled for use on Air-conditioning, Refrigeration, Ventilation and Central Monitoring and Control System Installation carried out for or on behalf of the ArchSD in Government Buildings of the HKSAR.

There are no representations, either expressed or implied, as to the suitability of this T&C Procedure for purposes other than that stated above. The material contained in this T&C Procedure may not be pertinent or fully cover the extent of the installation in non-government buildings. Users who choose to adopt this T&C Procedure for their works are responsible for making their own assessments and judgement of all information contained herein. The ArchSD does not accept any liability and responsibility for any special, indirect or consequential loss or damage whatsoever arising out of or in connection with the use of this T&C Procedure or reliance placed on it.

TABLE OF CONTENTS

	Page
1. Introduction	1
2. Objectives of the Testing and Commissioning Works	1 - 2
3. Scope of the Testing and Commissioning Works	2 - 9
3.1 Tests and Inspections during Construction	
3.2 Functional Performance Tests	
3.3 Statutory Tests and Inspections	
3.4 Documentation and Deliverables	
3.5 General Commissioning Requirements	
3.5.1 General Checking Procedure	
3.5.2 Codes for Commissioning Procedure	
3.5.3 Progressive Commissioning	
3.5.4 Specialist Commissioning	
3.6 General Testing Requirements	
3.6.1 Cleaning	
3.6.2 Tests under Operating Conditions	
3.6.3 Calibrated Equipment/ Instruments	
4. Testing and Commissioning Procedures	9 - 130
4.1 General Test and Inspection Requirements	
4.1.1 Work Tests	
4.1.2 Weld in Piped Services	
4.1.3 Pressure Testing of Piped Services	
4.1.4 Air Leakage Test for Ductwork	
4.1.5 General Electrical Checks	
4.1.6 Pre-commissioning Checks of Water Distribution System	
4.1.7 Pre-commissioning Checks of Air Distribution System	
4.2 Water, Air and Refrigeration Systems	
4.2.1 Water Distribution System	
4.2.2 Air Distribution System	
4.2.3 Refrigeration Systems	

- 4.3 Other Relevant Tests and Inspections
 - 4.3.1 Indoor Air Quality (IAQ)
 - 4.3.2 Energy Efficient Equipment & Systems
 - 4.3.3 Control Systems
 - 4.3.4 Noise and Sound Tests
 - 4.3.5 Vibration Tests
 - 4.3.6 Electrical Tests
 - 4.3.7 Final Air Conditioning System Performance Tests

Annex

		Annex Page
Annex I	Testing and Commissioning Progress Chart for Air-conditioning, Refrigeration, Ventilation and Central Monitoring & Control System Installation	1 - 21
Annex II	Testing and Commissioning Certificate on Air-conditioning, Refrigeration, Ventilation and Central Monitoring & Control System Installation	1 - 54
	1. Details of Project	
	2. Declaration	
	3. Items Inspected and Tested	
	4. Test Results and Records	
	4.1 Packaged Water Chillers	
	4.2 Air-Cooled Chillers	
	4.3 Cooling Towers	
	4.4 Pumps	
	4.5 Pump Alignment Test	
	4.6 Air Handling Units	
	4.7 Heating Coils (Not included in Air Handling Unit)	
	4.8 Ducts, Grilles, Diffusers etc.	
	4.9 Pressure Test	
	4.10 Evacuation Test	
	4.11 Air Duct Leakage Test Sheet	
	4.12 Fan Coil Unit	
	4.13 Variable Air Volume (VAV) Box	

4.14	Split Type Air Conditioning Units	
4.15	Variable Refrigerant Volume (VRV) System	
4.16	Water Scrubbers	
4.17	Exhaust Hoods	
4.18	Ventilation and Air Conditioning (VAC) interfacing with Fire Alarm Signal	
4.19	Outdoor Air Pre-conditioners (OAP)	
4.20	Noise & Sound Test	
4.21	Vibration Test – Equipment Vibration Measurement Record	
4.22	Room Temperature Record – Handover/ Peak Load/ Wet & Humidity Season/ Expiry of Maintenance Period	
4.23	Solar Water Heating System	
4.24	Checklist for Walkthrough Inspection	
4.25	Testing and Commissioning Results of IAQ Measurement	
4.26	Testing and Commissioning Records of IAQ Measurement of Real Time Monitor with Data Logging	
4.27	Testing and Commissioning Records of IAQ Measurement by Passive Sampler	
4.28	Testing and Commissioning Records of IAQ Measurement of Air Borne Bacteria	
Annex III	List of Calibrated Equipment/ Instruments Necessary for the Testing and Commissioning Works	1
Annex IV	Flow Charts	1 - 6
	Fig.1 Flow Chart for T&C Procedure	
	Fig.2 Sensor Checking Flow Chart	
	Fig.3 Digital Output (DO) Checking Flow Chart	
	Fig.4 Analogue Output (AO) Checking Flow Chart	
	Fig.5 Alarm Checking Flow Chart	
	Fig.6 Control Loop Checking Flow Chart	
Annex V	Reference for Testing and Commissioning Procedures	1 - 14
	1. Measurement Principles of Real-time IAQ Monitors	
	2. Example of Air Flow Sheet	
	3. Illustration of Balancing Procedures	

- 3.1 General Description of the Water Distribution System
- 3.2 Initial Check of System Water Flow Rates
- 3.3 Balancing of Terminals
- 3.4 Balancing of Complete Branches
- 3.5 Balancing of Secondary Pumps
- 3.6 Balancing of Primary Pumps
- 4. Principle of Proportional Air Balancing
 - 4.1 Preparation
 - 4.2 Regulating of Air Terminals
 - 4.3 Air Balancing of Sub-branches
 - 4.4 Air Balancing of Branch and Regulation of Total System Flow
 - 4.5 Regulation of Total System Flow
 - 4.6 Tolerances in Measurement

Testing & Commissioning Procedure for Air-conditioning, Refrigeration, Ventilation and Central Monitoring & Control System Installation

1. Introduction

The procedures stated in this Testing & Commissioning (T&C) Procedure cover the activities in preliminary tests and inspections, functional performance tests and the commissioning of newly completed installations and existing ones after major alteration. They are so compiled to facilitate the work of Project Building Services Engineer (PBSE) and Project Building Services Inspector (PBSI), who are appointed as the Supervising Officer's Representatives, in the following aspects with respect to testing and commissioning:

- (a) to vet and approve the T&C procedures proposed and submitted by the contractor for Air-conditioning, Refrigeration, Ventilation and Central Monitoring and Control System Installation (A/C Contractor);
- (b) to witness those T&C procedures as specified; and
- (c) to accept the T&C certificates and other supporting data.

The A/C Contractor shall carry out the T&C works as detailed in this T&C Procedure. Supplementary T&C plans may be proposed by the A/C Contractor as appropriate and agreed by PBSE, e.g. for special equipment supplied and/or installed by the A/C Contractor.

The administrative requirements for T&C works are in general as specified in the General Specification for Air-conditioning, Refrigeration, Ventilation and Central Monitoring & Control System Installation 2017 Edition and all current corrigenda/amendments thereto published before the date of first tender invitation for the Contract issued by the ArchSD (the General Specification).

All words and expressions shall have the meaning as assigned to them under the General Specification unless otherwise specified herein.

2. Objectives of the Testing and Commissioning works

The objectives of the T&C works are:

- (a) to verify proper functioning of the equipment/system after installation;
- (b) to verify that the performance of the installed equipment/systems meet with the specified design intent and statutory requirements, if any, through a series of tests and adjustments; and
- (c) to capture and record performance data of the whole installation as the baseline for future operation and maintenance.

For the avoidance of doubt, depending on the specific demands of individual installation, the PBSE may require additional or substitute T&C works in regard to any elements in the Installations other than those indicated in this T&C Procedure.

3. Scope of the Testing and Commissioning Works

3.1 Tests and Inspections during Construction

The purpose of these tests is to ensure that all components and systems are in a satisfactory and safe condition before start up. Preliminary adjustment and setting of equipment at this stage shall also be carried out at the same time to pave way for the coming functional performance tests.

Before carrying out any test, the A/C Contractor shall ensure that the Installations comply with all relevant statutory requirements and regulations. The T&C works shall also comply with all site safety regulatory requirements currently in force. In particular, the A/C Contractor shall note the following:

- (a) Electricity Ordinance (Cap. 406), and other subsidiary legislation;
- (b) Code of Practice for the Electricity (Wiring) Regulations published by the EMSD;
- (c) Occupational Safety and Health Ordinance (Cap. 509), and other subsidiary legislation made under the Ordinance;
- (d) Factories and Industrial Undertakings Ordinance (Cap. 59), and other subsidiary legislation made under the Ordinance, including but not limited to Construction Sites (Safety) Regulations; and
- (e) Electricity supply rules of the relevant power supply companies.

3.2 Functional Performance Tests

The purpose of functional performance tests is to demonstrate that the Installations can meet the functional and performance requirements as specified in the Specification. Functional performance tests should proceed from the testing of individual components to the testing of different systems in the Installations.

The A/C Contractor may have to make temporary modifications as the tests proceed. The specific tests required and the order of tests will vary depending on the type and size of systems, number of systems, sequence of construction, interface with other installations, relationship with the building elements and other specific requirements as indicated in the Specification. The testing of systems may have to be carried out in stages depending on the progress of work or as proposed by the A/C Contractor.

Part of the tests may be required to be carried out in suppliers' premises in accordance with the provisions in the Specification.

Any performance deficiencies revealed during the functional performance tests must be evaluated to determine the cause. After completion of the necessary corrective measures, the A/C Contractor shall repeat the tests.

If any test cannot be completed because of circumstances that are beyond the control of the A/C Contractor, it shall be properly documented and reported to the PBSE, who shall then liaise with the relevant parties to resolve the situation. The A/C Contractor shall resume his testing work immediately upon the attainment of a suitable testing environment.

3.3 Statutory Tests and Inspections

The A/C Contractor shall carry out tests for the Installations to meet statutory requirements as specified in the Specification. After the proper testing and commissioning of the Installations, the A/C Contractor shall notify the appropriate authority as specified in the Specification, through the PBSE of the completion of the Installations and its readiness for inspection and testing. The A/C Contractor shall arrange for the necessary inspections and tests as required by the Authority.

Statutory tests and inspections required for the Installations shall include, but not limited to, the following:

- (a) Water quality tests of fresh water cooling towers (FWCT) under the Public Health and Municipal Services Ordinance Cap 132
- (b) Tests and inspections related to the Installations under the Codes of Practice for Minimum Fire Service Installations and Equipment and Inspection, Testing and Maintenance of Installations and Equipment issued by FSD

3.4 Documentation and Deliverables

The A/C Contractor shall submit his proposed T&C procedures together with the Testing and Commissioning Progress Chart shown in Annex I to PBSE for approval.

All inspection and T&C results shall be recorded by the A/C Contractor in the appropriate test record forms. A complete set of these forms can be found in Annex II.

Data recorded in other formats may also be acceptable subject to prior approval of the PBSE. Upon completion of all the required T&C works, the A/C Contractor shall complete and sign a testing and commissioning certificate as shown in Annex II to the effect that the agreed T&C works have been duly carried out.

A functional performance test report covering all measured data, data sheets, and a comprehensive summary describing the operation of the system at the time of the functional performance tests shall be prepared and submitted to the PBSE. Deviations in performance from the Specification or the design intent should be recorded, with a description and analysis included.

Where required in the Specification, the A/C Contractor shall conduct a final evaluation of the performance of the Installations, the results of which shall be included in the commissioning report.

3.5 General Commissioning Requirements

3.5.1 General Checking Procedure

Systems shall be properly commissioned to demonstrate that all the equipment deliver the designed capacities and that air and water flow rates are balanced in accordance with the design.

Since the air systems are usually completed ahead of the hydraulic systems, commissioning of the air systems will commence earlier than the water systems.

Prior to any commissioning works, the A/C Contractor shall check the completion of the air-conditioning and ventilation associated builder's work and the building services installations, to ensure that commissioning can be proceeded without obstruction.

(a) Checking Procedures on builder's work:

- (i) Plantrooms are completed and free of construction debris;
- (ii) All plant room doors are fitted and lockable;
- (iii) Permanent power supply of sufficient capacity is available and the Building Contractor is operating a security access procedure to all plant areas to prevent unauthorised switching of plant.

(The normal security access system is one of "Permit to Work" arrangement and procedure proposed by the A/C Contractor in accordance with the guidelines on "Permit to Work" issued by the Labour Department.);

- (iv) All builder's work and building services installations in association with air-conditioning systems are satisfactorily completed;
- (v) All glazing works are completed and all windows closed;
- (vi) All curtain walls and the building fabric are completed and reasonably water-tight;
- (vii) All external doors, all stairs and lobbies, and toilet doors are completed and securable;
- (viii) All ceiling works are completed, unless specifically agreed, with the exception of those access areas required to be left open for final adjustment and testing of high level building services equipment during the commissioning period.

All dust generating activities by other trades are finished and all areas are thoroughly cleaned and sealed to prevent ingress dust from getting into the ventilation and air-conditioning systems during operation; and

(ix) All builder's work in association with pressurised and depressurised areas are completed.

(b) Checking procedures on Building Services Installation

The A/C Contractor should ensure that:

- (i) Air intake screens and louvres are unobstructed and clean;
- (ii) Fan and other equipment chambers are clean and free of construction debris;
- (iii) Floor gulleys and drainage traps are clear;
- (iv) Fans are checked for impeller housing clearance and free of foreign objects;
- (v) Heater batteries and cooler batteries are clean and fins combed;
- (vi) Cooling coil condensate trays and humidifier drains are unblocked;
- (vii) Dampers are clean;
- (viii) Ducting and other airways are clean;
- (ix) All electrical wiring circuits (power, lighting and controls) are completed, or will be completed at the correct stage during the commissioning period;
- (x) All electrical panels are commissioned and clean;
- (xi) Lighting systems are switched on;
- (xii) Permanent power supply is available at the electrical panels, and all the connected equipment can be switched on;
- (xiii) All equipment are checked for:
 - Equipment rotation (fan kicked only);
 - Lubrication;
 - Belt tension;
 - Motor fixings;
 - Duct flexible connector correctly aligned;
 - Keyway and setscrew tightness;
 - Clean condition;
 - Vibration isolation adjustment;
 - Correct operation of VAV control gear;
 - Correct overloads and amperages;

- Investigate and locate all stop-start, disconnect and circuit interruption devices; and
 - Inspect fan inlet and outlet to ensure satisfactory performance conditions are provided.
- (xiv) All outside air, return air and spill air dampers are operative;
 - (xv) All fire and volume control dampers are fitted and left in the fully open position;
 - (xvi) The supply air systems are blown through;
 - (xvii) All VAV and CAV terminals are installed, together with grilles and diffusers;
 - (xviii) All manual control valves are open or pre-set, as required;
 - (xix) All strainers are cleaned;
 - (xx) All water systems are flushed, vented and filled and chemical cleaning process is completed;
 - (xxi) Water treatment is completed;
 - (xxii) All filter media are installed;
 - (xxiii) Plantroom access is restricted to authorised personnel only; and
 - (xxiv) All functional and safety devices are installed and operational.

3.5.2 Codes for Commissioning Procedure

All aspects of the commissioning procedure shall follow the recommendations in the relevant CIBSE Commissioning Codes, including but not limited to:-

- (a) Preliminary checks to ensure that all systems and system components are in a satisfactory and safe condition before start up;
- (b) Preliminary adjustment and setting of all plant and equipment consistent with eventual design performance;
- (c) Energising and setting to work on all plants; and
- (d) Final regulation and demonstration that the installation delivers the correct rate of flow of fluids and air at the conditions specified in the Contract Documents.

3.5.3 Progressive Commissioning

The A/C Contractor shall not wait for completion of every part of the Installations but shall arrange for a progressive commissioning programme

to achieve practical overall completion and have the Installations ready to be handed over by a date to suit the Contract completion date or any other agreed programme date.

3.5.4 Specialist Commissioning

The A/C Contractor shall be responsible for initially setting the plants to work and shall arrange for any specialist plant or equipment such as Central Control and Monitoring System (CCMS) to be commissioned and tested by the specialist equipment manufacturer's skilled commissioning engineer and/or technician.

3.6 General Testing Requirements

3.6.1 Cleaning

Before any of the Installations is subjected to commissioning and site testing, it shall be thoroughly cleaned both internally and externally.

(a) Water System

- (i) The system (new or old) shall be flushed using an appropriate chemical dispersant of a type and strength recommended by a reputable chemical water treatment manufacturer and guaranteed in writing by that company as suitable in every respect for the application in question.
- (ii) The quality of cleaning water discharged shall comply with EPD requirement or treated if needed as stated in Clauses F5.1 (e) and F10 of the General Specification.
- (iii) The chemicals shall remain in the system for 48 hours including a minimum of 12 hours with the pumped circulation in operation, unless otherwise recommended by the supplier with substantiated technical support accepted by the Supervising Officer.
- (iv) After chemical cleaning, the system shall be flushed and drained immediately. The A/C Contractor or the chemical water treatment specialist shall continue to take water samples at all system low points until the water samples indicate iron and chemical residues below the level of 1 ppm.
- (v) The success or failure of the above operation will depend on a high speed rate of draining down which is entirely related to the size of the drain points and ability of air to enter the system from the top.
- (vi) For high speed draining down purposes the A/C Contractor shall provide temporary 50 mm valved drain outlets on all points where the main pipework is 50 mm dia. or over.

(vii) The A/C Contractor shall ascertain that there is adequate drainage nearby to discharge by large hose in order to ensure flooding of low level areas will not occur.

(viii) Subsequent to the flushing operations, the large drain down points shall be reduced to 15 mm valves or cocks or the sizes as indicated in the Contract Drawings.

(b) Air System

(i) Ductwork systems shall be cleaned by purging using the supply air fan, or robot duct cleaning as recommended by the ductwork system cleaning specialist. No fan shall be started until cleaning is commenced.

(ii) All submitted proposals for arrangements to ensure cleanliness of air and water systems shall follow the recommendations in the relevant CIBSE Commissioning Codes.

(c) Refrigerant system

The piping system shall be cleaned by purging using nitrogen before pressure test and evacuation test

3.6.2 Tests under Operating Conditions

The A/C Contractor shall include the hydraulic and functional performance tests under operating conditions, on the Installations to the entire satisfaction of the Supervising Officer.

3.6.3 Calibrated Equipment/ Instruments

3.6.3.1 A list of testing equipment/ instruments proposed by the A/C Contractor to be used for T&C (Annex III) must be agreed with the PBSE prior to commissioning the work.

3.6.3.2 The suggested items of equipment/ instruments & accessories necessary to comply with the T&C objectives are:

(a) sound level meter to BS EN 61672-1 [2013] and BS EN 61672-2 [2013] with built-in octave filter and sound level calibrator, Microphone Sensitivity: ± 2 dB, Resolution: 0.1dB;

(b) vibration meter to ISO 2954 [2012] for vibratory velocity in mm/s measurement, completed with vibration transducer (accelerometer), Accelerometer Sensitivity: $1\mu\text{C}/\text{ms}^{-2} \pm 2\%$, Resolution: 6%;

(c) inclined manometer in not less than 0.1 Pa (0.0005 in. of water) divisions;

- (d) combined inclined and vertical manometer 0-2000 Pa (0-10 in. of water);
- (e) pitot tubes (size 450 mm (18-in.) and 1200 mm (48-in.) long tube);
- (f) a tachometer, which should be the high quality, direct contact, self-timing type;
- (g) clamp-on ampere meter with voltage scales;
- (h) deflecting vane anemometer;
- (i) rotating vane anemometer;
- (j) thermal-type (hot-wire) anemometer;
- (k) dial and glass stem thermometers;
- (l) pressure gauges (Manifold & Single);
- (m) dial push/pull pressure gauge;
- (n) pressure tapings; and
- (o) coupling alignment dial gauge.

4. Testing and Commissioning Procedures

4.1 General Test and Inspection Requirements

4.1.1 Work Tests

- (a) Work tests shall be carried out in accordance with the type normally associated with the specified item of equipment and to the standards as laid down in the Contract.
- (b) Static pressure tests shall be carried out on items such as pressure vessels, water coils, plate type heat exchangers, radiator and convector elements, and all items of plant or equipment, as laid down in the Specification and Drawings.
- (c) Dynamic rotation tests shall be carried out on items such as fan impellers and drives, compressor, pump impellers and drives. Tests shall be conducted through the entire rotational speed range up to a maximum of 150% design operating speed if such provisions have been made in the Contract. When items of plant are purchased ex-stock, manufacturer's test certificate will suffice.

- (d) Rotational test on electric motors will not be carried out if the equipment is constructed to the related content of IEC standard, or any other approved standards.

4.1.2 Weld in Piped Services

- (a) The PBSE reserves the right to inspect at random 2% of the welded joints. Should any of the above welds prove faulty in materials or workmanship, further inspection of welds may be ordered up to a total of 4% of the welded joints. If any of the welds fail the tests, it is sufficient to conclude that the weld operative is not consistent in standard. The PBSE may order any number of the operative's welds to be removed. The A/C Contractor shall be responsible for cutting out and repair of all such welds for inspection.
- (b) At least 2 welds per operative shall be inspected. Each welder employed on the works shall be allocated an identification number and each site weld shall be stamped or marked with the appropriate identification number to identify the operative.
- (c) In addition to the above, each weld made on pipes and fittings having a nominal diameter of 350 mm and larger, and a 5% sample of all welds on pipes and fittings having 300 mm diameter and below shall be inspected by using an approved non destructive inspection process, e.g. radiographic or ultrasonic methods. The A/C Contractor's attention is drawn to the magnitude of this task, the constraints of the water mains, and the time frame within which testing must be carried out. Such non-destructive testing should be carried out by accredited laboratories that both perform the tests and analyse the results.

4.1.3 Pressure Testing of Piped Services

- 4.1.3.1 Before carrying out pressure test, spotted open-up inspection for joints shall be required to inspect the internal finishing after brazing to ensure the quality of the workmanship.
- 4.1.3.2 Refrigerant systems and circuits shall be pressure tested with nitrogen gas to test pressures as indicated below: -

Refrigerant	High Side Test Pressure kPa	Low Side Test Pressure kPa
R 134a (Air-cooled)	2080	1190
R 134a (Water-cooled)	1270	880
R 717 (Air-cooled)	3230	1820
R 717 (Water-cooled)	1940	1340
Others	*	*

* In performing pressure tests for refrigerant systems and circuits containing blend refrigerants (e.g. R407C and R410a),

manufacturer's recommended procedures and test pressures shall be followed.

4.1.3.3 Test Records

The method of recording the pressure tests shall be all as indicated in Clauses 4.1.6.6.5 and 4.1.6.6.6.

- (a) Prior to application of insulation and painting to the welded pipe joints and cleaned pipe surfaces, all water pipework shall be hydraulically pressure tested to 1.5 times the maximum working pressure of the system for not less than 12 hours or otherwise specified, without leakage or loss of pressure. The maximum working pressure shall be deemed to be the static head plus the total pump head. The minimum test pressure for water pipe is 1,000 kPa.
- (b) The pressure test shall be carried out in different sections of the hydraulic systems in such zoning approved by the PBSE.
- (c) Where any plant cannot withstand the maximum pipework test pressure, it shall be isolated during the pipework tests, and then the isolated plant shall be tested at its test pressure.
- (d) The A/C Contractor shall ensure that all plugs, caps, tees and drain fittings are provided to enable the pressure tests to be carried out.
- (e) Before hydraulic pressure tests are carried out, all safety valves, gauges, etc., shall be effectively isolated or removed. For all safety equipment, these shall be effectively tested at their design working pressure during commissioning of the Installations.
- (f) Tests on lengths of pipe or portions of systems shall be applied by filling the section to be tested with water up to its testing pressure.
- (g) The pressurised section shall then be left fully isolated without further strokes of the pump and all joints must remain watertight for a period of at least 12 hours. As to whether or not the section is sound shall be governed by the rate at which the pressure falls. The A/C Contractor shall agree with the PBSE on the acceptable percentage of pressure falls.
- (h) Any fault discovered during such tests shall be at once remedied and the test reapplied until the section under test is considered sound. Remedial work shall conform to all the requirements of the Specification for material and standards of workmanship.

- (i) Upon completion of the test, the water shall be released and drained away as rapidly as possible, the section being then thoroughly sluiced through to ensure the removal of as much dirt and dross as possible before being refilled and put into service.

4.1.4 Air Leakage Test for Ductwork

4.1.4.1 All ductwork shall be tested for air leakage in accordance with Clause B2.10 of the General Specification.

4.1.4.2 The joints on ductwork shall be tested for air leakage. All openings such as fan outlets, grilles, access panels, test holes, etc. shall be sealed before test:

- (a) Prior to application of insulation and painting, all installed ductwork, including exhaust, smoke extraction, air-conditioning, ventilation, etc., shall be tested to the requirements of the General Specification. The method of air leakage test shall follow the HVCA standard DW/series or the “Low Pressure Duct Construction Standards” and “High Pressure Duct Construction Standards” issued by the SMACNA of U.S.A. as directed by the PBSE. Air ducts shall be leakage tested and any defects shall be rectified before applying insulation and commissioning.
- (b) For preliminary and visual test, the method will include using chemical “white” smoke generator. All openings in the ductwork shall be properly sealed followed by the introduction of smoke.

4.1.5 General Electrical Checks

Prior to the initial running of any electrically driven pump, fan, valve, electric heater or automatically advancing filter, the following procedures should be adopted.

4.1.5.1 With all electrical supplies isolated, check:

- (a) the local isolation of motor and control circuits;
- (b) that there are no unshrouded live components within the panels;
- (c) that the panels and switchgears and heaters are clean;
- (d) that the motor and surrounding areas are clean and dry;
- (e) that the transit packing has been removed from contactors and other equipment;

- (f) that there is no mechanical damage to switchgears and heaters and that thermostats are of a suitable range to operate at ambient temperature;
- (g) that all mechanical checks on the pump, fan, motor, valve or automatic filter, where appropriate, are completed;
- (h) that all connections are tight on busbars and wirings;
- (i) that the internal links on the starter are correct;
- (j) that all power and control wirings have been completed in detail to the circuit diagram, paying special attention to circuit for star-delta connected or specially wound motors;
- (k) that the fuse and circuit breaker ratings are correct;
- (l) that the starter overloads are set correctly in relation to the motor name-plate full load current;
- (m) that the dashpots are charged with the correct fluid and the time adjustments and levels are identical;
- (n) that insulation tests on the motor have been performed satisfactorily;
- (o) that the adjustable thermal cut-outs are set correctly (check manufacturers' test certificates); and
- (p) that all cover plates are fitted.

4.1.5.2 With the electrical supply available, check:

- (a) check that the declared voltage range is available on all supply phases;
- (b) where motor powers are substantial or reduced voltage starting or complex interlocks are involved:
 - the control circuit logic and the starter operation shall be tested before the motor is rotated;
 - the supply should first be isolated; then by the withdrawal of 2 power fuses or disconnection of cables followed by reinstatement of supply to the control circuit alone, the control circuit shall be activated and starter operation observed; and
 - adjust the timer, check for proper operation of all contactors, relays and interlocks. Finally open the isolators, reinstate power connections and close the isolators, where appropriate.

- (c) where small motors have direct-on-line starting and simple control circuits, the starter operation, etc., should be checked when first starting the motor; and
- (d) never energise electronic valve motors until the checks specified have been completed.

4.1.6 Pre-commissioning Checks of Water Distribution System

4.1.6.1 System Cleanliness

Irrespective of the precautions taken during the construction stage to keep the internal surfaces of pipework clean, the following procedures shall be used to clean the system.

4.1.6.1.1 Flushing

- (a) divide the pipework system into self-draining sections so that the maximum possible flushing rate is achieved;
- (b) isolate or bypass items which are particularly sensitive to dirt such as pumps, chillers, small bore coils and tubes, including induction and other room unit coils and spray nozzles. Washers, cooling tower basins, feed and other tanks which may have accumulated with deposits during manufacturing or installation should also be isolated and flushed independently; and
- (c) where make-up or feed tanks are used for flushing, ensure that the maximum possible pressure is sustained on the system during the flushing process. This may necessitate the provision of a temporary parallel feed of mains water into the tank where the ball valve has limited capacity. This T&C Procedure assumes that the connection of the section from the tank is at a high point in the section being flushed. The flushing water wherever appropriate, shall be recirculated with suitable filtration to reduce the water demand and wastewater discharge.
- (d) Ensure:
 - (i) that flushing is carried out from the upper to the lower sections of a multi-section system, flushing with the lowest point; initial flushing should always be from small bore to large bore pipe. Particular care is required on reverse return systems and systems with roof-top chiller or boiler plant;

- (ii) that the large bore outlet is not opened until the section being flushed is fully primed;
- (iii) that the maximum possible flow rates are used; and
- (iv) that flushing continues until the outflow runs clear.

4.1.6.1.2 Cleaning by Forced Circulation

Where facilities exist, cleaning of systems can be achieved by circulation of the medium in order to collect dirt at filters or other selected points in the system. Where circulation is achieved by the use of a pump, this action shall be deferred until the pump has been set to work in accordance with Clause 4.2.1.4. The circulating velocity shall be 1.5 times of normal water velocity in pipe.

4.1.6.1.3 Chemical Cleaning & Corrosion Inhibiting

Chemical Cleaning, if required, shall be carried out as specified by the specialist. Corrosion inhibiting, where specified, should be carried out after flushing.

4.1.6.2 State of System

Check:

- (a) that where special valve packing is required, e.g. grease in medium or high temperature system, this shall be in accordance with manufacturer's instructions;
- (b) that pressure tests have been completed throughout;
- (c) that the system has been cleaned in accordance with Clause 4.1.6.1.1;
- (d) that permanent water connections have been made; and
- (e) that water treatment is available if specified.

4.1.6.3 Check of System before Filling

Check:

- (a) that probes, pockets, pressure gauges, siphons, orifice plates and taps, and air vents are installed;
- (b) that drains and overflows are connected and free from blockage;

- (c) that connections to heating and cooling coils and all other heat exchangers are correct in relation to the design water flow direction;
- (d) that control and non-return valves are installed the right way round;
- (e) that relief valves are installed as specified and are free to operate;
- (f) that relief valve outlets are piped away to suitable drain points;
- (g) the expansion devices for alignment and freedom from obstruction;
- (h) the presence of special pump priming devices where specified;
- (i) that the strainer meshes are of the correct grade and material;
- (j) that the changeover devices for duplex strainers are operative and that there are means of isolation for single strainers;
- (k) that washers, tanks, nozzles and filters are clean;
- (l) that tank covers are provided where specified;
- (m) that drain cocks are closed and other valves are left open or closed according to the plan for filling;
- (n) that the feed connection is in its correct location; and
- (o) that all pipework and fittings are adequately supported, guided and/or anchored where applicable.

4.1.6.4 Mechanical Checks

4.1.6.4.1 Pumps

Check:

- (a) the external cleanliness of the pumps, remove and clean and replace all strainers;
- (b) that the flow direction is correct;
- (c) that all components, bolts, fixings, tie bars etc., are secured;
- (d) that the impellers are free to rotate;

- (e) the level and plumb of pump and motor shaft and slide rails; (direct drive pumps require particular attention in this respect);
- (f) the anti-vibration mountings for correct deflection;
- (g) that the correct drivers are fitted;
- (h) that the pipework imposes no strain at the pump connections;
- (i) the securing and alignment of pulleys and couplings;
- (j) the belt tension and match;
- (k) the cleanliness of the bearings;
- (l) that the lubricant is fresh and of the correct grade;
- (m) that the coolant is available at the bearings when specified.
- (n) that glands are correctly packed and the gland nuts are finger-tight only, pending adjustment to correct drip rate after start-up; and
- (o) that drive guards are fitted and the access for speed measurement is provided.

4.1.6.4.2 Motorised Valves and Float Switches

Check:

- (a) that the valves are installed the correct way round;
- (b) that the valve spindles are free to move;
- (c) for freedom from excessive looseness;
- (d) the fit of pins;
- (e) the rigidity of the mountings;
- (f) the stiffness of the linkage members;
- (g) the tightness of locking devices; and
- (h) the bearing lubrication.

4.1.6.4.3 Cooling Towers

Check:

- (a) that the water-circulating system serving the tower is thoroughly cleaned of all direct and foreign matters;
- (b) that interior filling of cooling tower is clean and free of foreign materials such as scale, algae, or tar;
- (c) that the cooling tower fans are free to rotate and the tower basin is clean; and
- (d) that the water-circulating pumps are ready for test.

4.1.6.5 System Filling

4.1.6.5.1 All water tanks shall, after erection, be filled with water and shall remain filled for at least 24 hours during which all joints shall be carefully examined. Any defect shall be rectified immediately and the test repeated.

4.1.6.5.2 Before finally charging, the water systems shall be thoroughly flushed and all strainers, filters, etc. cleaned or replaced.

4.1.6.5.3 Charge the system with water by filling from the bottom upwards forcing the air to high points – for venting to atmosphere. Careful consideration should be given to the stage of valves and automatic air vents before and during filling to avoid air-locks and excessive spillage. Take care not to exceed the working pressure of the system when filling from a high pressure source. When the whole system is filled, disconnect the filling source, open the permanent supply and adjust the tank levels.

4.1.6.6 Hydraulic testing for water distribution pipe work systems

4.1.6.6.1 General

All water distribution pipework systems shall be hydraulically tested in sections as installation work progresses and before thermal insulation is applied.

4.1.6.6.2 Test Pressure

The hydraulic test pressure shall be 1.5 times the maximum working pressure of the system.

4.1.6.6.3 Precautions

Before hydraulic tests are carried out, all safety valves, gauges, etc. shall be effectively isolated or removed. These safety equipment shall be effectively tested at their design working pressure during commissioning of the Installations.

4.1.6.6.4 Method of Testing

For a satisfactory and acceptable test, the pressure shall be maintained for a period of 24 hours or as otherwise stated in the Particular Specification, without loss of pressure after all weak joints, defective fittings and pipes disclosed by the initial application of the test are rectified. During the final testing period the Supervising Officer or his Representative shall be invited to witness the tests. All sections of the work under test shall be accessible for inspection and selected welds shall be hammer tested.

4.1.6.6.5 Hydraulic Test Certificates

Certificates of all hydraulic tests made on the Site shall be forwarded to the Supervising Officer for approval and such approval shall be obtained before any thermal insulation is applied. A separate and duplicated set of the A/C Contractor's installation/shop drawings shall be provided for the purpose of keeping accurate records of site tests. One copy will be kept by the Supervising Officer or his Representative on the Site and the other retained by the A/C Contractor.

4.1.6.6.6 Details on Test Certificate

All test certificates shall be signed by the A/C Contractor and by the Supervising Officer or his Representative who has witnessed the test. All test certificates shall contain the following particulars :-

- Date of test
- Apparatus or section under test
- Makers number (if any)
- Nature, duration and conditions of test
- Result of test
- Name of A/C Contractor's representative (in block letter) in charge of test
- Name of Supervising Officer or his Representative at witness the test

A blank form of test certificate shall be submitted by A/C Contractor for Supervising Officer's approval prior to carrying out the actual test on the Site.

4.1.7 Pre-commissioning Checks of Air Distribution System

4.1.7.1 System Cleanliness

4.1.7.1.1 During Construction

Dust and debris should be prevented from entering the duct system as far as possible and the system inspected and cleaned as part of pre-commissioning steps.

4.1.7.1.2 During T&C, the following procedures should be adopted:-

- (a) ductwork systems shall be cleaned by purging using the supply air fan, or robot duct cleaning as recommended by the ductwork system cleaning specialist if employed;
- (b) temporary filter media shall be used where building work is still in progress during T&C, and replaced with clean filters for final measurements of flow rates;
- (c) computer room plants, in particular where under floor air distribution systems are used, should not be run before the rooms have been properly cleaned;
- (d) extraction systems should not be run whilst building work is in progress and dirt is present; and
- (e) where a specialist ductwork cleaning company is employed, system commissioning should not commence until cleanliness has been inspected and certified.

4.1.7.1.3 Prior to the fitting of air cleaning equipment, ensure that the environment is clean and then proceed to check the following for cleanliness:

- (a) air intake screens and louvres;
- (b) fan and other equipment chambers;
- (c) floor galley and all drainage traps;
- (d) fan internals;

- (e) heater and cooler batteries;
- (f) cooling coil condensate trays;
- (g) washer tanks;
- (h) humidifiers;
- (i) eliminators;
- (j) dampers and linkages;
- (k) ducting and other airways;
- (l) sensing elements; and
- (m) terminal units.

4.1.7.2 Air Regulating Devices and Other Components within Airways

Check:

- (a) that turning vanes, thermal insulation, acoustic linings, heating/cooling battery fins and sensing elements have been fitted without damage;
- (b) that heater and cooler batteries, humidifiers, filters, silencers, fire dampers, sail switches, volume control dampers etc., are installed correctly in relation to air flow;
- (c) the damper free-movement, clearances seating pinning to damper spindles, position of blades with respect to quadrant indication, relative positions of blades in multi-leaf dampers;
- (d) the control linkages on motorised dampers for alignment, rigidity, lubrication and free movement without slackness;
- (e) that dampers throughout the system are secured in open/close position, as desired, with damper actuators locked;
- (f) the free movement of fire dampers together with the location of, access to fit the of fusible link assembly and the correct rating of fusible link; all fire dampers are finally secured in open position;
- (g) that all adjustable louvers are set without deflection, i.e. normal to face of grille. Adjustable cones on diffusers are set either all in the fully up or all in the fully down position; and
- (h) that test holes are provided at strategic points for the measurement of branch and total air volume flow.

4.1.7.3 Visual Checks for Air Tightness

Check:

- (a) the builder's work for ducts and shafts are completed with air sealed;
- (b) access doors to plant equipment are sealed around the whole periphery;
- (c) ductwork joints, including flexible couplings are air tight;
- (d) inspection covers are fitted;
- (e) drainage water seals are intact; and
- (f) plugs or covers for test holes are fitted.

4.1.7.4 Mechanical Checks

4.1.7.4.1 Fans

The following should be checked:

- (a) internal and external cleanliness of fans;
- (b) all components, bolts, fixing, etc. are secured;
- (c) impeller secured, free to rotate, of correct handing and correct clearances;
- (d) axial-flow-type fans installed for correct air flow direction and, where compounded, in correct order;
- (e) level and plumb of fan and motor shaft and slide rails;
- (f) anti-vibration mountings for correct deflection and the removal of transit bolts and packing materials;
- (g) the static balance;
- (h) correct drive is fitted;
- (i) securing and alignment of pulleys and couplings;
- (j) belt tension and match;
- (k) cleanliness of the bearings;
- (l) lubricant is fresh and of the correct grade;

- (m) coolant is available at bearings when specified;
- (n) drive guards fitted and access for speed measurement provided;
- (o) satisfactory operation of inlet guide vanes over full range of movement; and
- (p) fan casings to be earthed are correctly and soundly bonded.

4.1.7.4.2 Automatic Fabric Roll Filter

- (a) Check level mounting;
- (b) Check alignment, clearances and free movement of spools, drives and limit switches; and
- (c) Check lubrication of spool drive motor, gearbox and spool bearings.

4.1.7.5 Automatic Recleanable High Voltage Electrostatic Filter

4.1.7.5.1 Before approaching the filter, establish:

- (a) what isolators must be opened and fuses withdrawn to completely disconnect the filter plant from the low voltage supply. Beware of interlocking circuits which are energised from elsewhere and cannot be isolated locally to the filter;
- (b) the arrangements for preventing access to any high voltage component until it is earthed; and
- (c) adequate labels for instructions /precautions /warnings to be displayed at the entrance access to the filter.

4.1.7.5.2 With all low voltage supplies isolated, check:

- (a) the local isolation of all low voltage circuits;
- (b) that switchgears are clean and undamaged;
- (c) that the transit packing has been removed from contactors and other equipment;
- (d) that all wiring connections are tight;
- (e) that all wirings have been completed according to circuit diagram; and

- (f) that all cover plates are fitted.

4.1.7.5.3 High Voltage Electrical System

Only Registered Electrical Worker(s) with recognised training from the filter supplier on maintenance of high tension portion of the equipment should be allowed to enter the filter casing; the responsible person/team should have the interlock key which controls the opening of the access door to the section of filter which he is entering or a fuse link or other item to prevent the filter being energised; a second person should be stationed outside the door as an observer and he will normally also be in control of the operation of the power pack from this position. Before working on any filter system, any residual High Tension (H.T.) charge must be discharged using an earthing tool with insulated handle. Where the power pack is remote from the filter, a shorting bar should be securely fixed between earth and each H.T. feed to the filter.

The inbuilt features which prevent access to high voltage components shall, without fail, shall be checked as follows:

- (a) no access to filter section via inlet or outlet ductwork connections. Where equipment is being used as a barrier, beware of items which are demountable without tools such as pre-filter cells. Such items should always be supplemented by safety screens as should dampers with blade width exceeding 100 mm;
- (b) any mechanical interlock correctly links H.T. circuits to earth before access door can be opened and simultaneously de-energises the H.T. primary circuit to prevent overload caused by the earth link;
- (c) no duplicate keys on the Site for the mechanical interlock system;
- (d) any safety switches fitted to access doors break the Low Tension (L.T.) interlock circuit and destroy.

H.T. potential before the door is open wide enough to allow an arm or leg to reach a H.T. component within the filter casing; also check that switches are held positively open to prevent manual closure or closure by spring failure whilst access door is open;

- (e) check that H.T. potentials are reduced to a safe level within the time it takes to open the door and reaches any H.T. component. This will be of particular importance when door safety switches do not merely augment a mechanical interlock earthing system but are also the sole safety interlock, the value of bleed resistors connected across each capacitor holding H.T. charge will be critical; and
- (f) a solid copper or aluminium bond connects the H.T. power pack and filter frame to the building's main earthing system.

4.1.7.5.4 Cleanliness and Mechanical Condition

With all electrical supplies isolated, H.T. circuits earthed and precautions for staff adopted in accordance with Clause.4.1.7.5.3. Check:

- (a) for unsafe ladders, walkways or dangerous projections;
- (b) the internal cleanliness of casing, components, including insulators and ductwork connections;
- (c) that all components are in place and correctly connected; no damage or distortion to ioniser and collector sections; no obvious foreign items in the filter cells; ioniser wires of the correct diameter and type to be provided and to be correctly tensioned; displacement of these wires from the centres between neutral electrodes should not exceed 5% of the distance between the neutral electrodes; no distortion of collector plates and gaps between plates shall not vary by more than 10%;
- (d) that the wash water and fluid coating systems are completed; reservoir is charged with correct fluid and drainage systems are completed and free from blockage; connection is provided for manual wash; and
- (e) that fabric alter sections are loaded with media; if automatic advancing then checks listed in Clause.4.1.7.4.2 shall be carried out.

4.1.7.5.5 Interlock Sequence and Alarm Systems

With electrical supply available check:

- (a) that the filter interlock sequence is correct; and
- (b) that all safety and failure alarm systems and function correctly.

4.2 Water, Air and Refrigeration Systems

4.2.1 Water Distribution System

4.2.1.1 General

The system as detailed in Annex V Fig.V includes only those plant items necessary for clarification of the regulation method described. The procedure given here may have to be adapted to suit the particular arrangement.

The method of manual regulation detailed below is applicable to the following systems :

- (a) constant volume, variable temperature primary circuits;
- (b) constant volume, variable temperature secondary circuits; and
- (c) the maximum flow situation in a variable volume system designed without diversity.

4.2.1.2 Procedures

This section defines the procedures to be carried out in order to achieve a water distribution system, which works satisfactorily and is regulated appropriately. These works should normally be carried out with the medium at ambient temperature and therefore there is no need for heated or chilled water to be available. It is unwise, in any event, to conduct the commissioning of heating or refrigeration plant (particular if of low thermal capacity) before design primary circulation flow rates have been established and any likelihood of primary flow rate variations due to modulation of unbalanced secondary systems have been eliminated.

4.2.1.3 Checks Prior to Pump Start-Up

- (a) check that all normally open isolating and regulating valves are fully open and that all normally close valves are closed. In the case of thermostatic valves it is essential that provision for fully opening of the valves is available. Most electric motorised valves have either provision for manual override of normal control using a switch on the main control box or a facility to position the valves seat mechanically;
- (b) check that the direction signs of all valves are the same as the water flow direction;

- (c) check that the horizontal or vertical alignment of all flexible joints is within the tolerances recommended by manufacturers' installation guideline;
- (d) open all control valves to full flow to heat exchangers of branch circuits; and
- (e) fully open the return and close the flow valve on the pump, close valves on standby pump. Closing the flow valve on the duty pump will limit the initial starting current, which is usually excessive at the first time a pump is running due to bearing stiffness.

4.2.1.4 Initial Running of Electrically Driven Centrifugal Pump Set

4.2.1.4.1 Initial start

On activating the motor starter at initial start, check that:

- (a) the direction and speed of rotation of the motor shaft are correct;
- (b) the motor, pump and drive are free from vibration and undue noise;
- (c) the sequence timing adjustment of star-delta starters, auto-transformer starters, etc. is set in accordance to motor starting current;
- (d) the motor running current on all phases are balanced and do not exceed motor nameplate rating. The flow valve can be opened at this point to raise the running current to say 50 per cent of the name-plate full load current;
- (e) there is no sparking at the commutator or slip rings for d.c. or slip ring motors;
- (f) there is no overheating of the motor (see BS EN 60947-4-1 [2010]+A1 [2012] and BS EN 60034-3 [2008]);
- (g) there is no seepage of lubricant from the housing;
- (h) the water flow to water-cooled bearings is sufficient;
- (i) the ventilation systems of air-cooled motors are operating correctly; and

- (j) the motor running current are correctly matching with the speed as specified by manufacturer's pump data sheet on multi-speed motors.

4.2.1.4.2 Initial run

- (a) ensure that a light load should be sustained until the commissioning engineer is satisfied from the checks listed in Clause 4.2.1.4.1 and from motor insulation test readings that further load may be applied. Repetitive starting of the motor should be avoided to prevent over-stressing of the fuses, switchgear and motor;
- (b) gradually open the discharge valve from closed position until the motor current reaches either the design value or the motor full load current, whichever is the lower;
- (c) check the pump pressure developed by means of the pump altitude gauges against the design pressure. If excessive pressure is developed at this stage, the cause should be investigated and rectified; and
- (d) adjust the discharge valve so that the flow as determined roughly from the pump characteristic is between 100 and 110 per cent of the design value.

Note that the motor full load current is not exceeded.

4.2.1.4.3 Running-in period

- (a) the pump should be run in accordance with the manufacturer's recommendations and should be under fairly continuous observation. It should not be left running outside normal working hours unless attended;
- (b) ensure that a means of temporarily bypassing the terminal units liable to choking be completed in advance as a parallel circuit of each coil for AHUs/Chillers;
- (c) check that the bearings and motor temperature remain steady, that no noise or vibration develops and that no bolts or fixing works is loose;
- (d) close the valves to the AHUs/Chillers and other vulnerable units to avoid blockage at the coils of terminal units;

- (e) vent all high points from time to time. When possible the medium should be heated to maximum permissible levels to assist in removing air from the heating system;
- (f) adjust the gland nuts of the pump glands to give the correct drip rate; (not applicable to mechanical seals.) and
- (g) after 8 hours of running, check all strainers. If these are clean, regulation can commence. Otherwise, clean the strainers and run again for at least 8 hours and then re-check.

(Remark: Observations afterwards may then become less frequent, but it is advisable, while commissioning other parts of the system later, to check the pump from time to time.)

4.2.1.4.4 Standby Pump

- (a) on installations with a standby pump, the standby pump should also be commissioned;
- (b) this pump can be checked against the other duty pump. In the unlikely event of failure of the duty pump, commissioning can continue using standby pump; and
- (c) carry out a full diagnosis of the reasons for the failure of the duty pump before energising the standby pump to ensure that any contributory causes are remedied.

4.2.1.4.5 Secondary Pump

- (a) in systems with primary and secondary pumps, starting procedures for the primary pumps should be dealt with first;
- (b) isolate the secondary system during this period to prevent any accumulated deposits not removed during the flushing process being carried over into the secondary services;
- (c) after the final check of strainers referred to in Clause 4.2.1.4.3, the secondary system can be opened up and the starting procedure for the secondary pumps initiated; and

- (d) only after a final check of both primary and secondary strainers should actual regulation commence.

4.2.1.5 Regulation of Water Flow

4.2.1.5.1 Principles of water flow rate measurement & registration

- (a) the installation location of the devices shall follow the manufacturers' recommendation in order to obtain accurate flow measurement results. The devices may be a venturi-meter, an orifice plate, a control valve with known calibrated flow characteristics, a calibrated regulation valve, electromagnetic flow sensors or any device with a constant flow coefficient and calibration chart;
- (b) referring to Fig. 4.2.1.5.1, the pressure drop across the device is proportional to the square of the water flow rate. Hence the actual-to-design water flow is given by;

$$\frac{Q_1}{Q_2} = \sqrt{\frac{\Delta P_1}{\Delta P_2}}$$

- where
- ΔP_1 = Actual pressure drop in kPa
 - ΔP_2 = Design pressure drop in kPa
 - Q_1 = Actual water flow rate in m³/s
 - Q_2 = Design water flow rate in m³/s

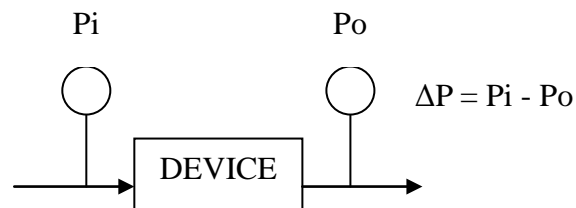

Fig. 4.2.1.5.1 Pressure drop across a device

- (c) water flow regulation is achieved by varying the water flow across the device followed by measuring the pressure drop across it until the actual-to-design flow rate is within the tolerance acceptable by the PBSE; and
- (d) recommended tolerances for flow rate balancing in chilled water systems should not exceed 0% to (+)10% with the exception of terminal units where flow rate is small (<0.1 l/s). For small flow rates, the tolerances for index unit should be within (-)7.5% to (+)15% and for other circuits, they

should preferably be within (-)5% to (+)5%. The pressure differential signal of a suitable device should be between 1 kPa and 10 kPa.

4.2.1.5.2 Illustration of Balancing Procedures

For details, refer to Reference no. 3 of Annex V.

4.2.1.6 Automatic Water Balancing (AWB)

If so specified in the Particular Specification or the Contract Drawings, AWB system shall be adopted. Balancing shall be carried out to meet specified water flow with tolerance as recommended in Clause 4.2.1.5.1. The A/C Contractor shall provide all necessary balancing valves with actuators and Direct Digital Controllers (DDCs), flow measuring devices and all interface necessary equipment for CCMS connection in order to achieve automatic water balancing.

The AWB system shall perform 3 main functions, namely, (1) water balancing for system commissioning, (2) monitoring of the flow rates and (3) re-balancing of water due to change of load profile. The AWB shall be so designed to achieve a fully automatic control in performing the water balancing. No on-field adjustment, measurement and testing during the water balancing shall be required. The only step is to input the design flow rates to the CCMS and observe the change from the monitor and revise input data if any.

4.2.1.6.1 Method of Balancing

- (a) The A/C Contractor shall provide a computer programme with a compact algorithm for water system balancing. Such algorithm completed with water circuit diagram and location of balancing valves shall be submitted within 3 months after the commencement of the Contract for approval.
- (b) The algorithm shall be designed to achieve the water balancing using the logic of the procedure as outlined in the General Specification and Clause 4.2.1.5. After completion of the pre-water balancing procedure as specified in Clause 4.1.6, the AWB system shall balance all water circuits by operating the motorised balancing valves through the CCMS.

4.2.1.6.2 Hardware and software

Any necessary hardware and software such as DDC controllers, sensing devices, operating software and self-diagnostic devices of the AWB are deemed to be included in the Contract. The AWB is an integral part

of the CCMS and any standards or requirement not specified in this section shall refer to the relevant Sections and Clauses or CCMS specified in the Contract. The communication protocol shall comply with the ASHRAE's BACnet standards, or relevant international standards as stated in Clause C5.3 of the General Specification.

4.2.1.6.3 Pre-commissioning Consideration

The A/C Contractor shall select the motorised modulating control valve and design the algorithm in achieving a stable AWB system. The A/C Contractor shall supply and install any additional items and/or modification works required for achieving a stable system at no additional cost.

The AWB system shall balance all water circuit as specified in the Particular Specification or the Contract Drawings to a steady balanced state. The CCMS system shall coordinate with the control of all other system such as chiller plant to complete the balancing. The input design flow data and balancing point of each motorised balancing valve shall be logged and password protected in the CCMS. Power shall not be required to maintain motorised modulating control valves at the balancing point.

Only the person with authority shall change the flow rates and re-balance the water circuit. The password shall be at least 64-bit encrypted and stored in the CCMS. The flow rate and temperature at each motorised balancing valve shall be displayed with colour graphic layout diagram on the computer monitor and updated at intervals agreed by PBSE.

The colour graphic layout diagram shall show the location and number of motorised balancing valves on the background of the schematic water flow diagram with floor level and room name. The CCMS shall generate and print out, if requested, tables showing the actual flow rates, design flow rates and the corresponding percentage difference of the water passing through motorised modulating control valves against their location and floor level. The difference between the input design flow rates and actual flow rates shall be in accordance with Clause 4.2.1.5.1.

The algorithm and corresponding colour graphic layout diagram shall be easily updated for any modification of water circuit.

4.2.1.6.4 Demonstration

The A/C Contractor shall perform dummy testing by inputting at least 20 sets of water flow rates or as specified in the Particular Specification to test the stability of the AWB system and the timing required for adjusting. The values of the dummy testing water flow rates shall be submitted for approval at least 2 weeks before T&C. Any electronic measuring equipment for use with automatic water balancing shall be provided by the A/C Contractor and permanently installed at designated location at no additional cost.

4.2.1.7 Balancing Water Circuits

4.2.1.7.1 Method of Balancing

The A/C Contractor shall balance all circuits by operating the regulation valves provided. Fluid flow through the cooling and heating coils shall be adjusted to provide the design air temperature drop or rise.

4.2.1.7.2 CIBSE Commissioning Code 'W'

In general, the system shall be balanced using the procedure as outlined in the CIBSE Commissioning Code "W" - Water Distribution Systems.

4.2.2 Air Distribution System

4.2.2.1 Precautions Against Airborne Dirt

The system should have been cleaned internally in accordance with Clause 4.1.7.1 but further precautions shall be taken before starting the fans for the first time:

- (a) disconnect final flexible connections to terminal units such as induction units and blender boxes;
- (b) preferably remove all high efficiency terminal filters;
- (c) check that suitable temporary protection has been provided for anything within the spaces served by the system which could be damaged by initial discharge of dust from supply outlets at first starting;
- (d) install main inlet filter cells, properly coated as necessary, to avoid introducing additional dirt into the ductwork system after start-up;
- (e) check seating of cells for air tightness; and

- (f) commission automatic fabric and electrostatic filters in accordance with Clauses 4.2.2.2 and 4.2.2.3.

4.2.2.2 Automatic Fabric Roll Filter

The scope of the test is to verify effective performance of the automatic fabric roll filter in accordance with the manufacturer's technical information and/or the stated requirements in the Particular Specification. The general test procedures for the unit is:

- (a) preliminary checks in accordance with Clause 4.1.7.4.2 shall have been completed;
- (b) install filter media in accordance with manufacturer's instructions;
- (c) energise the filter without air flow;
- (d) with the differential pressure control device looped out, close the isolator controlling supply to filter and test operation by the manual advance switch;
- (e) leave the filter on manual advance until the correct total air flow through the filter is established;
- (f) the correct total air flow through the filter shall be established as part of the procedure for regulation of air flow (see Clause 4.2.2.5 below);
- (g) commission the differential pressure controller after establishment of correct air flow as described in (see Reference no. 4 of Annex V) for which the clean filter condition will normally have been manually selected;
- (h) an inclined manometer with pressure sampling points adjacent to the filter fabric will be used to measure the prevailing static pressure drop across the clean filter and this will be recorded;
- (i) the filter may then be progressively blanked off (e.g. with cardboard) until the manometer indicates the design 'dirty filter' pressure drop;
- (j) the differential pressure control will be adjusted to start advancing the filter at this 'dirty filter' pressure drop and to stop advancing the filter at the design clean filter pressure drop; and
- (k) Filter performance shall be tested according to ANSI/ASHRAE Standard 52.2-2012 – Method of Testing General Ventilation Air-Cleaning Devices for Removal Efficiency by Particle Size.

4.2.2.3 Automatic Recleanable High Voltage Electrostatic Filter

The scope of the test is to verify effective performance of the automatic recleanable high voltage electrostatic filter in accordance with the manufacturer's technical information and/or the stated requirements in the Particular Specification. The general test procedures for the unit is:

- (a) only Registered Electrical Worker(s) with recognised training from the filter supplier on maintenance of high tension portion of the equipment should be allowed to enter the filter casing;
- (b) the responsible person/team should have the interlock key which controls the opening of the access door to the section of filter which he is entering or a fuse link or other item to prevent the filter being energised;
- (c) a second person should be stationed outside the door as an observer and he will normally also be in control of the operation of the power pack from this position;
- (d) before working on any filter system, any residual H.T. charge must be removed using an earthing tool with insulated handle; and
- (e) where the power pack is remote from the filter a shorting bar should be securely fixed between earth and each H.T. feed to the filter.

4.2.2.3.1 Preliminary Checks

Under no circumstance shall commissioning proceed until all checks listed in Clause 4.1.7.5 have been completed.

4.2.2.3.2 Water Wash and Fluid Coating Systems

- (a) commission the wash and coating systems in accordance with Clauses 4.1.6 and 4.2.1;
- (b) adjust sequence timers; and
- (c) the filter should be washed prior to initial energising and if specified coated with fluid, allowing correct drainage period to elapse. (Note : This may be a matter of hours.)

4.2.2.3.3 Automatic Fabric Filter Sections

Commission any automatic fabric filter sections in accordance with Clauses 4.1.7.4.2 and 4.2.2.2.

4.2.2.3.4 Initial Energising of Filter Without Air Flow

- (a) check that no one is inside filter casing, that access doors are closed and that no entry can otherwise be made to the filter interior;
- (b) cancel and lock out any remote control system for filter;
- (c) switch on filter;
- (d) check that there is no flash-over problem and that indications from meters and lamps on filter control panel are normal;
- (e) all safety measures listed in Clause 4.1.7.5.3 must be implemented before entry to the filter casing; and
- (f) restore full automatic control sequence and make it ready for the establishment of air flow through the filter.

4.2.2.3.5 Application of Air Flow to Filter

When air flow is established through the filter (see Clause 4.2.2.4.5):

- (a) check that there is no excessive flash-over (say, an average of over 5 per minute per square metre of the face area);
- (b) an inspection should be made on the de-energised filter after a few hours operation with air flow established (see Clause 4.2.2.4.5);
- (c) the H.T. voltage shall be checked at ioniser and collector sections. Unless otherwise specified the H.T. voltage should be within +3% of the nominal figure specified at the mean declared L.T. voltage;
- (d) polarity should normally be arranged with positive voltage on the ioniser section to limit ozone generation;
- (e) measurement of H.T. voltage shall be by means of an instrument comprising high stability resistance chain with high sensitivity millimetre in series, or electrostatic voltmeter across 1 section of the chain;
- (f) only a skilled and experienced operator should attempt measurement of H.T. voltage. Great care

is necessary to avoid contact with live parts of the meter and no part of the meter or its connections should be touched when it is connected to H.T. components; any such connections should normally be special H.T. cables to avoid current leakage;

- (g) readings should normally be made with the meter placed within the filter casing and observed from the outside through the observation window;
- (h) the correct total air flow through the filter shall be established as part of the procedure for regulation of total air flow (see Reference no. 4 of Annex V);
- (i) the uniformity of air velocity distribution across the face of the de-energised filter bank should be checked using an anemometer after the regulation of total air flow (see Reference no. 4 of Annex V). To do this, it will be necessary to override the interlock with the supply fan;
- (j) single point measurements of indicated velocity should be made at the centre of each 300 mm square of the face area, and where appropriate instrument correction factors shall be applied to each of the readings;
- (k) the mean indicated velocity is then calculated and each of the point readings is expressed as a percentage of this mean. The percentage variations of velocity must be within the tolerances specified; and
- (l) upper limits will always be critical and a failure to meet the specified tolerances must be rectified.

4.2.2.3.6 Filter Performance

Filter performance shall be tested according to ANSI/ASHRAE Standard 52.2 – 2012 – Method of Testing General Ventilation Air-Cleaning Devices for Removal Efficiency by Particle Size and equipment shall be tested to meet Underwriters Laboratories UL Standard 867 [2011] - Electrostatic Air Cleaners.

For kitchen application, oil mist and odour removal performance shall be verified by recognised testing laboratory and equipment shall be tested to meet Underwriters Laboratories UL Standard 710 [2012] - Exhaust Hoods for Commercial Cooking Equipment (for Fire and Burnout Test only).

4.2.2.4 Initial Running of Electrically Driven Fan Set

4.2.2.4.1 Limit the Load

- (a) wherever possible the first start of any motor should be on light load;
- (b) with centrifugal fan sets this will normally be achieved by limiting the mass flow by operation of the main damper. The fan characteristics must be available so that excessive suction or delivery pressure is not applied to the ductwork system.

4.2.2.4.2 Initial Start

On activating the motor starter, check:

- (a) that the direction and speed of rotation of motor shaft are correct;
- (b) that the motor, drive and fan are free from vibration or undue noise;
- (c) the motor starting current for sequence timing adjustment;
- (d) the motor running current on all phases;
- (e) that there is no sparking at commutator or slip rings;
- (f) that there is no overheating of motor (see BS EN 60470 [2001]);
- (g) that there is no seepage of lubricant from the housing;
- (h) that there is no overheating of the bearings;
- (i) that oil rings are running freely;
- (j) note the reduced speed rev/s and the motor running current on multi-speed motors;
- (k) the rev/s of fan and motor; and
- (l) visually / audibly check the performance of fan belts in case of abnormal vibration.

4.2.2.4.3 Initial Run

- (a) a light load run shall be sustained until the PBSE/PBSI is satisfied from the checks listed in Clause 4.2.2.4.2 above; and
- (b) repetitive starting of the motor should be avoided to prevent over-stressing of fuses, switchgear and motor.

4.2.2.4.4 Start at Normal Load

- (a) after the initial light load run, the machine shall be stopped and restarted at normal starting load, and the checks listed in Clause 4.2.2.4.2 repeated; and
- (b) avoid repetitive starting.

4.2.2.4.5 Running-in Period

- (a) after a short run at normal load (a few minutes' run will normally suffice) flexible connections to terminal units, etc., and terminal filters (which were removed in Clause 4.2.2.1) shall be restored to position;
- (b) subsequently a running-in period shall be sustained until the fan set is in a reliable continuous running condition; and
- (c) the regulation of the air distribution system shall be delayed until the running-in period (which may last for a few days) is completed satisfactorily.

During the running-in period the following work shall be conducted:

- (d) the dynamic balance of the fan and motor shall be investigated and corrected if necessary; and
- (e) the performance of electrostatic filter shall be checked (see Clause 4.2.2.3).

4.2.2.5 Regulation of Airflow

4.2.2.5.1 State of the System and Building

Before starting the regulation of airflow, check that the following conditions are fulfilled:

- (a) relevant building features are completed and consistent with their normal state. Windows and doors are opened or shut as appropriate;

- (b) should (a) be impractical, make appropriate provisions (temporary blanking-off or opening etc.) to simulate the normal state of the spaces under test;
- (c) in exercising (a) & (b) above, maintain flexibility with reference to requirements in (g) below;
- (d) the duct system is completed and practically leakage-free and in the case of a high velocity system, pressure testing is satisfactory;
- (e) the requirements of checks listed in Clause 4.1.7 have been met;
- (f) the corresponding cooling and heating systems (including duct heaters) shall normally be shut off, except for fresh air systems, some cooling or heating may be applied to the main duct only for air tempering purpose; and
- (g) the associated air supply or extract system that has not been regulated should normally be shut down and the duct system under regulation shall be balanced against atmosphere i.e. with doors or windows open (or purpose-made provisions) to maintain the relevant spaces under atmospheric pressure.

4.2.2.5.2 Balancing Air Flow Circuits

- (a) airflow tests shall commence as soon as a ducting system and fan are installed and wired up. In some instances, temporary electrical supplies to fans may be necessary in order to test ductwork under working conditions;
- (b) the A/C Contractor shall balance all air diffusers and grilles by regulating the dampers provided. Each system of ductwork shall be balanced so that every branch duct, diffuser, grille and pressure relief valve shall carry the required quantity of air;
- (c) Generally, the test procedure shall comply with that set out in the CIBSE Commissioning Code "A" - Air Distribution Systems; and
- (d) after completion of the balancing, all dampers, grilles, diffusers, etc. shall be locked in position with permanent marking and the A/C Contractor shall demonstrate to the Supervising Officer that the Installations comply with the Particular Specification and that the air distribution is

balanced in accordance with the air flow details shown in the original Contract Drawings or as later instructed.

4.2.2.5.3 Principle of Proportional Air Balancing

For details, refer to Reference no. 4 of Annex V.

4.2.2.6 Variable Air Volume System

- (a) the self-balancing system characteristic requires little actual air balancing work. The exercise is targeting on verifying the performances of the VAV boxes and fan airflow discharge in response to changes in controlling parameters;
- (b) check that the system is clean, to avoid damage to VAV box components. Check that Site conditions in Clause 4.2.2.5.1 are met, unless otherwise stipulated below;
- (c) fully review the recommendation from supplier in the setting to work and commissioning of both VAV box and variable airflow device. Adhere to these recommendations to avoid damages due to improper handling;
- (d) obtain fan curves and surge characteristics;
- (e) for a variable speed drive operating on variable frequency control, obtain data pertaining to the change of fan motor speed and corresponding airflow with the change of frequency. For a vortex damper control, obtain similar data against the change of damper setting. Determine the maximum and minimum fan speed or damper settings;
- (f) construct a theoretical system curve with approximate surge area. The system curve initiates at the minimum inlet static of the boxes, plus system loss at minimum flow and terminates at design maximum flow;
- (g) for variable speed control, the operating range is between “the minimum speed that can produce the necessary minimum box static at lowest flow while still remaining in the fan’s stable range” and “the highest speed necessary to obtain maximum design flow”;
- (h) for inlet vane damper control, the operating range is between “the surge line intersection with the system curve” and “the maximum design flow”;
- (i) set the fresh/exhaust/recirculation dampers in either full fresh air or full recirculation positions;
- (j) set the supply and extract fans systems to their minimum speed conditions. Start the fans, and gradually increase the airflows.

Motor running current checks should be made at various increments, to prevent overloading. Check that the fans are operating within the extreme conditions identified from (e);

- (k) check system static pressures at or close to the positions specified for the pressure sensor for automatic regulation of fan speed, and at VAV boxes near to the fan. This is to prevent over-pressurisation of system components;
- (l) should abnormal excessive current or pressure are detected in (j) or (k) above, check for any improper settings. Refer to the designer for unresolved problem;
- (m) with fan motor current and system pressure not being exceeded, increase the airflow to the maximum design condition;
- (n) verify the VAV box factory settings on maximum and minimum flows with change in controlling parameter (e.g. actuator responses to voltage fluctuation according to temperature change). Also check intermediate settings. This must be done according to the VAV manufacturer's recommendations;
- (o) in conducting the exercise in (n) for a particular box, it may be necessary to throttle airflow to other boxes/branches in order to bring the one at test with sufficient pressure and flow;
- (p) in conducting (n), a sufficient number as agreed by PBSE/PBSI of boxes should be checked to be representative of the system. If a wide variation occurs, it may be necessary to check all the boxes;
- (q) check that the least favoured VAV box is also operating at the system's minimum design airflow;
- (r) for VAV box delivering air to a number of secondary terminals, air balancing of these terminals should be carried out according to Reference no. 4 of Annex V;
- (s) repeat (h) to (n) for different design conditions dictating the flows of fresh air and recirculation;
- (t) in the above processes, the fan drive mechanism will have to be repeatedly adjusted. Do this in accordance with the fan drive manufacturer's recommendations;
- (u) take readings of all above measurements and settings;
- (v) review the data and work in conjunction with the control specialist to arrive at the desired fan drive settings and VAV box settings; and

- (w) it is important to ensure that pressure sensors for fan airflow control are so located that they offer responsive, stable and reliable regulation across the full range of fan operation. Should the pre-determined positions not be appropriate, reflect this to the PBSE.

4.2.2.7 Pressure Differential Between Spaces

There are systems designed to achieve a pressure differential between spaces served, for purpose of isolation or containment. Airflow in hospital from clean area to less clean area is one of the applications. The following actions shall be taken:

- (a) check that Site conditions in Clause 4.2.2.5.1 are met, unless otherwise stipulated below;
- (b) check that suitable paths for make-up or spill air are provided. Open all doors and hatches between the pressurised spaces;
- (c) run the supply or extract fan;
- (d) balance the air terminals in accordance with Reference no. 4 of Annex V;
- (e) set the fan airflow rate to design requirement;
- (f) close all doors and hatches so that the space is in its normal operating condition;
- (g) run the other extract or supply fan previously not in operation;
- (h) balance the system previously not balanced;
- (i) set up and commission pressure control devices in accordance with manufacturer's recommendations;
- (j) set the fan airflow rate to design requirement;
- (k) re-check airflow rates of previous system;
- (l) if the flow rates are within specified tolerance, the balancing work is completed;
- (m) if the readings are not within tolerance, re-check the system balance described in (d) & (e) above and, where necessary, make adjustments to reinstate the balance of the previously set total volume flow rate. Reiterate this step until no further adjustment is required; and
- (n) measure and record the pressure differentials between all adjacent spaces and compare the measurements with the specified design requirements.

4.2.2.8 Dual Duct System

- (a) dual duct system comprises a cold duct and a hot duct, respective air to be mixed in a mixing box before discharging to air-conditioned space at the appropriate dry and wet bulb temperatures. The cold duct usually can handle 85% to 100% of system flow, and the hot duct 40% to 80% flow;
- (b) check that Site conditions in Clause 4.2.2.5.1 are met, unless otherwise stipulated below;
- (c) start balancing by setting all room control thermostats for maximum cooling, fully opening the cold air valves;
- (d) proceed to the extreme end of the system (longest duct run) and check the static pressure drop across the box. The reading should exceed or equal the minimum static pressure recommended by the manufacturer of the box (about 185 Pa static pressure is common for the mechanical regulator);
- (e) for mixing boxes that are not factory preset, set the mechanical volume regulator in accordance with manufacturer's recommendation. Refer to calibration curve wherever appropriate;
- (f) measure airflow of all air terminals;
- (g) for mixing box delivering air to a number of secondary terminals, air-balance them according to Reference no. 4 of Annex V;
- (h) air-balance the flow from boxes to Reference no. 4 of Annex V should relevant dampers be available and the readings in (f) indicate unacceptable tolerances. Make adjustment to box air valve if necessary in accordance with manufacturer's recommendation;
- (i) change the control settings to full heating and make certain that the controls and dual-duct boxes function properly; and
- (j) measure airflow from all air terminals and check against design. For out-of range mixing box, make adjustment to the air valve if necessary in accordance with manufacturer's recommendations.

4.2.2.9 Automatic Air Balancing (AAB)

If so specified in the Particular Specification or the Contract Drawings, AAB system shall be adopted. Balancing shall be carried out to meet the specified airflow with tolerance level as recommended in Reference no. 4 of Annex V. The A/C Contractor shall provide all necessary motorised volume control dampers,

airflow measuring devices and all interface equipment necessary for CCMS connection in order to achieve AAB.

The AAB system shall perform 3 main functions, namely, (1) air balancing for system commissioning, (2) monitoring of the airflow rates and (3) re-balancing of air due to change of load profile. The AAB shall be so designed to achieve a fully automatic control in performing the air balancing. No on-field adjustment, measurement and testing during the air balancing shall be required. The only step is to input the design airflow rates to the CCMS and observe the change from the monitor and revise input data if any.

4.2.2.9.1 Method of Balancing

The A/C Contractor shall provide a computer program with a compact algorithm for system balancing. Such algorithm completed with air side schematic diagram and location of motorised volume control dampers shall be submitted within 3 months after the commencement of the Contract for approval.

The logic of the algorithm shall be designed to achieve the air balancing using the procedure as outlined in the General Specification and Clause 4.2.2. After the completion of the pre-air balancing procedure as specified in Clauses 4.1.7 and 4.2.2.5, the AAB system shall balance all air circuits by operating the motorised volume control dampers through the CCMS.

4.2.2.9.2 Hardware and Software

Any necessary hardware and software such as DDC controllers, sensing devices, operating software and self-diagnostic devices of the AAB are deemed to be included in the Contract. The AAB is an integral part of the CCMS, any standards or requirements not specified in this section shall refer to relevant Sections and Clauses or CCMS specified in the Contract.

4.2.2.9.3 Pre-commissioning Consideration

- (a) The A/C Contractor shall select the motorised volume control dampers and design the algorithm in achieving a stable AAB system. The A/C Contractor shall supply and install any additional items and/or modification works required for achieving a stable system at no additional cost.
- (b) The AAB system shall balance all air circuit as specified in the Particular Specification or the Contract Drawings to a steady balanced state. The CCMS system shall coordinate with the control of all other systems such as AHUs and FCUs to

complete the balancing. The input design flow data and balancing point of each motorised volume control damper shall be logged and password protected in the CCMS. Only the person with authority shall be able to change the flow rates and re-balance the air circuit. The flow rate and temperature at each motorised volume control damper shall be displayed with colour graphic layout diagram on the computer monitor and updated at intervals agreed by PBSE.

- (c) The colour graphic layout diagram shall show the location and number of each motorised volume control damper on the background of the airflow schematic diagram with floor level and room name. The CCMS shall generate and print out if requested tables showing the actual flow rates and design flow rates of the air passing through motorised volume control dampers against their locations and floor level. The A/C Contractor shall select suitable hardware and software such as flow meter, actuators, DDC and the operating system to achieve overall performance of the AAB in accordance with Reference no. 4 of Annex V.
- (d) The algorithm and corresponding colour graphic layout diagram shall be easily updated for any modification of air circuit.

4.2.2.9.4 Demonstration

The A/C Contractor shall perform dummy testing by inputting at least 20 sets of airflow rates or as specified in the Particular Specification to test the stability of the AAB system and the timing required for adjusting. The values of the dummy testing air flow rates shall be submitted for approval and at least 2 weeks before T&C. Any electronic measuring equipment for use with automatic air balancing shall be provided by the A/C Contractor and permanently installed at their location at no additional cost.

4.2.2.9.5 Motorised Volume Control Dampers

Motorised volume control dampers shall be tested in accordance with the recommendation of the manufacturer to assure automatic air balancing. All dampers provided shall also comply with the relevant Section of the General Specification.

4.2.2.10 Air Handling Units (AHUs)

The T&C of air handling units should be carried out in line with the General Specification and the items as specified below.

4.2.2.10.1 Operation

- (a) AHU systems must be in operation before the test and balance procedures are started; and
- (b) all controls must be installed, calibrated and fully operational.

4.2.2.10.2 Inspection

- (a) inspect the system to determine if it is complete and operable; check on the condensate drains, etc.;
- (b) verify that the drives are installed properly and are of the correct size and type. Verify that the inlet vanes are working;
- (c) refer to the pre-requisites for balancing;
- (d) verify that the fan wheels are on a single shaft. If they are on a split shaft, then verify that the shafts are properly connected to the drive end; and
- (e) verify that the filters are clean and of correct size and type.

4.2.2.10.3 Procedures

- (a) check the fan for proper operating condition and the fan motor shall be below the full-load current rating;
- (b) measure and proportionally balance the air distribution if the total discrepancy is within 20% of esign. If not, investigate and make adjustments as required;
- (c) locate a traverse position in a straight section of duct. Refer to the 'Pitot Tube Traverse' procedures;
- (d) traverse to determine fan airflow. Flow should be 100 to 110% of design assuming 0% air leakage;
- (e) adjust fan speed to obtain 100 to 110% of design airflow (m³/s) ;

- (f) measure power requirements before and after adjustments; and
- (g) after completing the balancing procedure, record the following minimum data on the report form as indicated in Annex II, whichever appropriate. They are:
 - (i) unit design data;
 - (ii) airflow (m³/s) from duct or coil traverse;
 - (iii) electrical power measurement procedure;
 - (iv) test the power in kW, if applicable;
 - (v) all nameplate data must be identified and verified;
 - (vi) test the motor rpm and fan rpm;
 - (vii) drive sizes, belt type, size and number;
 - (viii) centre-to-centre distance of the motor-base travel;
 - (ix) static pressure profile according to the static pressure profile procedure; and
 - (x) temperature across coils according to the coil capacity testing procedures.

4.2.2.10.4 Compliance

- (a) to comply with this T&C Procedure, complete all of the above steps and record all data on the report forms; and
- (b) all deficiencies that affect the above T&C works should be resolved by the installing contractor(s) and well include the deficiencies into the report.

4.2.2.11 Pretreated Air-handling Units (PAUs)

All the procedures are similar to Clause 4.2.2.10 for AHUs except the testing is for constant outside air coming directly into contact with the units.

4.2.2.11.1 Operation

- (a) the systems must be put in operation by the A/C Contractor; and

- (b) access must be provided by the A/C Contractor.

4.2.2.11.2 Inspection

- (a) inspect the system to determine if it is complete and operable; check on the condensate drains, etc.;
- (b) verify that the drives are installed properly and are of correct size and type;
- (c) refer to pre-requisite for balancing;
- (d) verify that the fan wheels are on a single shaft. If they are on a split shaft, then verify that the shafts are properly connected to the drive end;
- (e) verify that the filters for the outdoor air are clean and of correct size and type; and
- (f) verify that the coils are piped correctly.

4.2.2.11.3 Procedures

- (a) set and test the outside air quantity that could meet the minimum requirement as specified;
- (b) balance the systems that distribute outdoor air directly to the space to the quantities specified;
- (c) on systems that distribute air directly to other air-handling units, verify that the outside air is properly mixed with the return air so the mixed-air temperature is uniformly entering the coil. If the air temperature is not uniform, treat it as a deficiency;
- (d) verify that the outside air quality remains constant under all modes of operation;
- (e) test and set the outside air and verify that the minimum airflow rate (m^3/s) stays constant. Verify that the outside system air operates when occupied and when the exhaust system is on; and
- (f) measuring and setting outside air.
 - (i) the preferred method of measuring outside air is by duct traverse. Use Pitot Tube Traverse method to test;
 - (ii) an air capture hood is an acceptable method for measuring small outside air requirements, such as a unit ventilator or fan coil unit; and

- (iii) velocities at intakes are acceptable when an appropriate factor can be field determined by Pitot Tube Traverse.

4.2.2.11.4 Compliance

- (a) to comply with this T&C Procedure, complete all of the above steps and record all data on the report forms; and
- (b) outside air which makes up with the return air is also a consideration required in balancing the outside air, and should be reported if not included in the minimum outside air requirement.

4.2.2.12 Fan Coil Units (FCUs)

This T&C Procedure applies to all chilled water fan coil units including the high static equipment.

4.2.2.12.1 Operation

- (a) the system must be put in medium speed operation unless otherwise specified; and
- (b) proper access must be provided.

4.2.2.12.2 Inspection

Inspect the system to determine if it is complete and operable; check the condensate drains, etc.

4.2.2.12.3 Procedures

Use the following procedures for chilled-water fan coil units:

- (a) use manufacturer's rated airflow unless ducted, then use a duct traverse to determine airflow. If duct traverse is impossible, then use summation of the outlet readings;
- (b) set outside airflow to design specifications;
- (c) measure entering and leaving air dry and wet bulb temperatures;
- (d) measure entering and leaving water temperatures;
- (e) use the room conditions to determine the cooling load;

- (f) if a flow station is installed, then measure and record the flowrates (l/s) and compare to the heat-balance flowrate;
- (g) measure and record the water pressure drop across the coil and compare to the design. Only rely upon pressure drop for flow determination if other means noted are impossible to obtain;
- (h) measure and record all unit data;
- (i) measure and record motor operating amperage /voltage and compare against full-load nameplate; and
- (j) verify that controls operate properly and are in correct sequence. Note any deficiencies and record.

4.2.2.12.4 Compliance

Compliance with this T&C Procedure is met when the above are completed and the units are balanced to within the limits of the system.

4.2.2.13 Test on Water Scrubber / Kitchen Exhaust Hood

The scope of the test is to verify effective performance of the water scrubber / kitchen exhaust hood and its associated facilities in accordance with the manufacturer's technical information and the stated requirements in the Particular Specification. The general test procedures are:

- (a) the mechanical and electrical installations shall be visually inspected, tested in conformance with manufacturer's technical installation guide and information;
- (b) re-sealing test holes shall be provided at the main discharge duct for total air flow and static pressure measurements. The test hole position shall be determined on the Site. Test holes usually shall not be drilled on the bottom side of air duct;
- (c) the exhaust air fan shall be generally tested in accordance with relevant sections for fan, and noise measurement shall be in accordance with relevant section;
- (d) the water circulating pumps should be generally tested in accordance with relevant section for pumps;
- (e) the capture velocity or slot velocity at the hood face or entry slots shall be measured according to the appropriate standards; such as ANSI/ASHRAE 41.2-1987 and ANSI/ASHRAE

70-2006 on the recommendations by the Associated Air Balance Council (AABC) U.S.;

- (f) water curtain profile at the hood entry shall be visually checked and water consumption shall be metered throughout the test period;
- (g) the mist eliminators shall be installed in correct position and excessive air mists shall not be allowed;
- (h) integrated fire suppression installations, if provided shall be tested in accordance with the engineered system recommendation;
- (i) when the whole installation is featured with two speed flow control modes, the test procedures shall be carried out for both modes;
- (j) after completion of test, the air flow pattern around the hood entry shall be further verified with smoke candle. The smoke candle shall be positioned 300 mm below hood face and 150 mm around the hood periphery;
- (k) during test of hood exhaust system, the general kitchen ventilation systems shall be put in operation;
- (l) the overall result shall be documented in an approved test sheet; and
- (m) Oil mist and odour removal performance shall be verified by recognised testing laboratory and equipment shall be tested to meet Underwriters Laboratories UL Standard 710 [2012] - Exhaust Hoods for Commercial Cooking Equipment.

4.2.2.14 Outdoor Air Pre-conditioner, Heat Wheel and Air Heat Exchanger

4.2.2.14.1 Preliminary checks

The A/C Contractor shall carry out all visual checks and preliminary checks as recommended by the supplier/manufacturer before start up of the equipment. In addition, electrical checks shall be carried out as per Clause 4.1.5.

4.2.2.14.2 The following general procedures shall be adopted where applicable:

- (a) verify that all seals are properly installed and adjusted;
- (b) measure and record the flow rate of air entering the exhaust section;

- (c) measure and record the flow rate of air leaving the outside air section;
- (d) measure and record the dry and wet bulb temperature of air entering and leaving the exhaust side;
- (e) measure and record the dry and wet bulb temperature of air entering and leaving the outside air side;
- (f) calculate and record the sensible and total capacity of each airstream;
- (g) measure and record the pressure drop on each side of the heat exchange section;
- (h) measure and record the starting and running current of the equipment; and
- (i) measure and record the noise level where applicable.

4.2.2.15 Split Units and Variable Refrigerant Volume (VRV) System

4.2.2.15.1 Preliminary checks

The A/C Contractor shall carry out all visual checks and preliminary checks as recommended by the supplier/manufacturer before start up of the equipment. In addition, electrical checks shall be carried out as per Clause 4.1.5.

4.2.2.15.2 Commissioning tests

- (a) The following tests shall be carried out where applicable: static pressure test, dynamic rotation tests and inspection of welds in piped services;
- (b) Pressure and leak tests of refrigerating piping systems are normally carried out on completion of the system, before pipework is insulated; and
- (c) System evacuation, dehydration and charging with refrigerant shall be carried out by skills and experienced personnel.

4.2.2.15.3 The following are general procedures to be adopted.

- (a) check that the indoor and outdoor units are installed according to supplier's instructions and recommendations including maximum pipe run, etc;

- (b) check that the safety devices and necessary operational control are provided as per requirements of the General Specification;
- (c) check that pipeworks of correct pipe sizes are installed and insulation is completed;
- (d) check that the units are correctly wired up;
- (e) ensure that the connection nuts are tightened;
- (f) ensure that the system has been properly evacuated and leak-tested;
- (g) open all isolating valves where appropriate;
- (h) trial run the units after water drainage test;
- (i) measure the following and note down in the record sheet:
 - (i) starting and running current;
 - (ii) high and low pressure cut-out;
 - (iii) compressor suction and discharge pressure;
 - (iv) evaporator entering and leaving coil temperature, both WB and DB;
 - (v) condenser entering and leaving coil temperature, both WB and DB;
 - (vi) air flow rate;
 - (vii) noise level measurement as necessary;
 - (viii) other measurements as necessary for VRV systems; and
- (j) test the control system according to design where applicable.

4.2.3 Refrigeration Systems

4.2.3.1 General

T&C of refrigeration system shall be carried out by the skilled and experienced persons preferably assigned by the original manufacturer.

Normally the refrigeration systems are categorised by the following species (not exhaustive).

- (a) Reciprocating Compressor Systems (See Clause 4.2.3.2) ;
- (b) Centrifugal Compressor Systems (Including Oil Free Compressor) (See Clause 4.2.3.3);
- (c) Absorption Systems (See Clause 4.2.3.4);
- (d) Screw Compressor Systems (See Clause 4.2.3.5);
- (e) Scroll Compressor Systems (Details should be referred to Manufacturer's recommendation.); and
- (f) Split Units and VRV System (See Clause 4.2.2.15).

The following points are common to all systems and require careful handling:

4.2.3.1.1 System Cleanliness

- (a) The chilled water and condenser water systems should be flushed thoroughly by following the procedures as described in Clause 4.1.6.1 and the precautions below:
 - (i) isolate or bypass items which are particularly sensitive to dirt, including the shell and tube evaporators, condensers, pumps, spray nozzles and automatic water valves, and so on; and
 - (ii) where appropriate, remove the strainer screens, cooling tower basins, tanks and other equipment which may have accumulated deposits during manufacturing or installation, and shall also be isolated and flushed independently.
- (b) check the following items for cleanliness:
 - (i) isolate or bypass items which are particularly sensitive to dirt, including the shell and tube evaporators, condensers, pumps, spray nozzles and automatic water valves, and so on; and
 - (ii) air intake screens;
 - (iii) fan chambers of condensers and cooling towers;

- (iv) fan internals;
- (v) external heat exchanger surfaces of air-cooled condensers, evaporative condensers and cooling towers;
- (vi) sensing elements;
- (vii) cooling tower basins, evaporative condenser tanks and chilled water tanks;
- (viii) compressor, motor and drive;
- (ix) safety and control devices; and
- (x) drains and overflows.

4.2.3.1.2 State of the Systems

(a) Water System

For chilled water and condenser water systems, carry out the T&C procedures as listed in Clauses 4.1.6 and 4.2.1 in addition to the following.

Check :

- (i) that the cooling tower fill is complete and secured;
- (ii) that where chilled water tank is provided the tank lid is fitted and secured;
- (iii) the valve connection (where specified) for blow-down from cooling towers and evaporative condensers; and
- (iv) that any splash guards for cooling towers and evaporative condensers are fitted properly.

(b) Air System

For air handling systems and any airways associated with the air-cooled condensers, evaporative condensers and cooling towers, carry out the following checks.

Check:

- (i) that the airways are clear;

- (ii) that the condenser heat exchangers are installed correctly in relation to air flow;
- (iii) where applicable, the damper free movement, clearances, seating, pinning to damper spindles, relative positions of blades in multi-leaf dampers;
- (iv) that dampers are secured in open position with, where motorised, the actuator disconnected; and
- (v) the airways including builder's ductwork for air-tightness, noting particular seals at equipment, access doors, flexible connections, and junctions of all ductworks.

(c) Refrigerant System

Check:

- (i) that the pipework is complete and secured;
- (ii) that the thermostatic expansion valve (or float level device) is fitted : thermal bulb is correctly fitted and secured, external equaliser (where appropriate) is fitted;
- (iii) that the safety and control devices are fitted : such as the low pressure and high pressure cut-out, oil pressure cut-out (where fitted), chilled water low temperature thermostat, low water flow safety device and any protective solenoid valves being specified;
- (iv) that the liquid line strainer, isolating valves as specified, sight glass with moisture indicator and drier are fitted;
- (v) that the suction, discharge and oil pressure gauges with isolating valves are fitted and isolated from the system;
- (vi) that purging and charging connections are fitted; and
- (vii) if liquid receiver is provided, the capacity, associated works and the surveyor's certificate (if specified) are to be checked before commissioning.

(d) Checking of Water System before Filling

4.2.3.1.3 Carry out all checks where appropriate as described in Clause 4.1.6.3.

4.2.3.1.4 Mechanical Checks

(a) Fans

Carry out checks as described in Clause 4.1.7.4.1.

(b) Compressors

Check:

- (i) external cleanliness;
- (ii) that all components, bolts, fixings, etc., are properly secured;
- (iii) that the compressor shaft is free to rotate (applicable to open type compressor only);
- (iv) level and plumb of compressor and motor shaft and slide rails (applicable to open type compressor only);
- (v) anti-vibration mountings for correct deflection;
- (vi) to secure and align the pulleys and couplings (if applicable);
- (vii) belt tension and match of pulleys (if applicable);
- (viii) that drive guards are fitted, the access for speed measurement is provided and nipple extension for motor lubrication is provided (if applicable);
- (ix) correct oil level in compressor;
- (x) that the compressor unloading gear is fitted (if specified);
- (xi) any special arrangements for motor cooling; oil cooling where appropriate; and
- (xii) that vibration eliminator and muffler are fitted.

(c) Drives

For gear boxes and special mechanical drives pulley/belt, direct or flexible couplings for compressor or large cooling tower fans.

Check:

- (i) that the lubrication and pre-lubrication are in order before starting;
- (ii) that drive mountings are secured;
- (iii) that all shafts are correctly aligned; and
- (iv) for free rotation.

4.2.3.1.5 Electrical Checks

- (a) With all electrical supplies isolated, electrical check shall be carried out according to Clause 4.1.5, also check:
 - (i) wiring from all safety devices and liquid line solenoid valve are completed; and
 - (ii) compressor crankcase heater(s) is/are fitted and the wiring is completed.
- (b) With electrical supplies connected, electrical check shall be carried out according to Clause 4.1.5, also check:
 - (i) check for satisfactory operation of any electrical controls associated with compressor starter operation such as liquid line solenoid valve, electrical timing heater on the oil failure control (in this case, check for satisfactory operation and then temporarily disconnect it), and capacity unloading if initiated electrically;
 - (ii) where automatic sequencing starting for the whole refrigeration plant and associated chilled water and condenser water pumps is specified:
 - check that the sequence is correct in order and timing;
 - adjust timers, check for clean operation of all contactors, relays and interlocks; and

- finally open the isolators, reset or reconnect any device as appropriate, reinstate power connections and close isolators;

4.2.3.2 Reciprocating Compressor System

4.2.3.2.1 Pressure and Leakage testing

Refrigeration system working and test pressures shall comply with the requirements stipulated in the Specification.

(a) Factory Assembled Packaged Units

- (i) pressure & leak test, evacuation and dehydration & charging, either as a small holding charge or the full amount, should have been carried out at the factory;
- (ii) observe pressure gauge readings and
 - if the gauge readings are unsatisfactory, the whole programme of pressure testing, evacuation and charging must be carried out again;
 - if the gauge readings are in order, then pressure testing and evacuation are not required; and
 - where the system has a holding charge, additional charging is necessary.

(b) Built-up Systems

Pressure and leakage testing shall be carried out on completion of the system, before pipework is insulated and condenser is filled up with water:-

- (i) charge the system with a small amount of the refrigerant. The refrigerant acts as a tracer for leak detection purpose;
- (ii) charge the entire system to the desired test gauge pressure in accordance with manufacturer's instructions using dry nitrogen;
- (iii) pressure should be applied to compressor to test the vulnerable oil lines, etc. Precautions to be made on applied pressure to avoid

damages to the shaft seal (applicable to open drive system only) and

- checked all joints for leakage by electronic leak detector, then follow by using a soap solution “bubble” test;
 - pay attention to the gasket joints, bolt heads and nuts, sight glasses, welded joints, parting lines on castings, gauges and gauge connections, relief valves, evaporator and condenser water boxes; and
 - on hermetic units, pay attention to the motor terminals; on open machines, check the shaft seals;
- (iv) if leaks are identified, the gas and refrigerant in the system must be evacuated for fixing leakage area, and the system shall be recharged and tested again;
- (v) repair any leaks found in the system. Leaks must not be repaired while the system is under pressure;
- (vi) when the system is found to be free from leakage, allow it to stand for a minimum of 24 hours under pressure. If no pressure drop occurs (allowing for effect due to changes of ambient temperature) the system is ready for evacuation; and
- (vii) relieve test pressure to atmosphere, reconnect all lines and reinstate all items removed or isolated.

4.2.3.2.2 Evacuation and Dehydration

This shall be carried out by specialists assigned by the equipment manufacturer/ supplier.

4.2.3.2.3 Associated Air Systems

- (a) setting to work and adjusting air handling plant shall be carried out in accordance with Clauses 4.1.7 and 4.2.2; and
- (b) for systems employing direct expansion air coolers, check that commissioning of the main air distribution plant has progressed sufficiently through Clause 4.2.2 so as

- (i) to enable some measure of heat exchange to take place at the cooler;
- (ii) to allow limited running of the refrigeration plant for initial commissioning purposes; and
- (iii) to carry out the relevant parts of Clause 4.1.7 and all of Clause 4.2.2.4 for equipment on the condenser side of the refrigeration plant.

4.2.3.2.4 Charging

This shall be carried out by specialists assigned by the equipment manufacturer/ supplier.

4.2.3.2.5 Setting to Work and Adjusting

(a) Procedures

All procedures as outlined in Clauses 4.2.3.1, and 4.2.3.2.1 to 4.2.3.2.4 shall be completed before commencing this section. Chilled water and condenser water systems shall be checked in accordance with Clause 4.1.6 and the setting to work procedures in Clause 4.2.1 shall be proceeded at least to a point where sufficient water flow is available to enable full capacity conditions of the refrigeration plant to be checked.

(b) System Checks

Before operating the compressor continuously for the first time, a further visual check shall be carried out on the complete system, and in particular all refrigeration safety controls shall be put through their complete cycle of operation, including:-

- (i) set refrigeration pressure controls in accordance with manufacturer's instructions or ensure that all factory settings are in the right positions:
 - adjust compressor low pressure switch to cut-in whenever suction pressure rises above the desired gauge setting, with the differential set as wide as possible to prevent short-cycling in accordance with the manufacturer's recommendation;

- adjust high pressure switch to the recommended gauge settings; and
 - adjust oil pressure switch to the recommended setting;
- (ii) ensure all sequence and safety interlocks are operating correctly;
- (iii) in case the electronic expansion valve is employed:
- take refrigerant temperature at a point as close as possible to the remote bulb of the thermostatic expansion valve at the evaporator suction outlet, to enable proper superheat measurement to be made;
 - the suction pressure shall be read at a gauge installed in the back-set port of the compressor suction valve and converted to temperature reading using the refrigerant table; and
 - the difference between the thermometer reading at evaporator suction outlet and the temperature calculated from suction pressure is the superheat (usually about 5°C to 6°C);
- (iv) if abnormal pressure drop is suspected (suction lines are normally designed for 0.07 bar maximum pressure drop), steps shall be taken to reveal the reason;
- (v) check that the condenser water valves are open and the pressure or temperature actuated valves (where fitted) are operative;
- (vi) check the condensing system to ensure design air (if appropriate) and/or water quantities at required temperatures are available to enable the desired high side pressure to be maintained;
- (vii) check the associated thermostatic control system as described in Clause 4.3.1. Set the controlling devices (e.g. chilled water, room air, or return air thermostat, or pressure switch, or humidistat) to the desired settings;

(viii) check, immediately prior to commencing a continuous running test of the refrigeration system:

- that all refrigerant circuit shut-off valves are in open position, except for the bypass valves; especially ensure that the condenser liquid line valve is open;
- that all chilled water and condenser water circuit valves are in the correct positions;
- that compressor suction and discharge valves are open. Oil, suction and discharge pressure gauge throttling valves are open;
- that solenoid stop valves of evaporator are working on magnetic coil control
- that lubricating oil is visible (at centre, or above) in sight glass on compressor sump; and
- that electrical supply is available to the crankcase heater and the heater is all right. In case of a cold plant, at least 1 hour of operation shall elapse prior to running to enable the heater to boil off any refrigerant; and
- press the reset buttons on refrigerant pressure control(s), oil pressure control and freeze protection thermostat and/or freeze protection pressure switch.

(c) Start-Up

- (i) test and ensure free movement of all rotating parts of each compressor. Disconnect drive coupling or vee-belt. Check the correct direction of motor (applicable to open type compressor only);
- (ii) start on 'manual' control of the chilled water pump (or relevant fan) and condenser water pump and condenser fan (or relevant pump). If controls are arranged for sequenced 'auto' start only, proceed straightly to the automatic start; and

- (iii) start the compressor and observe for plant with both 'manual' and 'auto' selection, after 2 or 3 successful 'manual' operations change over to automatic control and check:
 - direction of rotation of compressor;
 - that motor, drive, and compressor are free from vibration or undue noise;
 - motor starting current; and
 - oil and refrigerant pressure gauges.

(d) Shut-Down

- (i) if the plant has 'auto' controls, operate an automatic shut down. Check that all sequencing and any special shut down requirements are operated satisfactorily;
- (ii) if the plant is arranged for manual control, proceed through the correct relevant sequence to shut the complete plant down; observe whether all automatic or safety features are operated satisfactorily; and
- (iii) in either case above note whether anything abnormal occurs during the shut down cycle (such as noise, vibration, or unexpected pressure variation).

(e) Running-In

When all of Clauses 4.2.3.2.5 (b)(i) to 4.2.3.2.5 (b)(iv) have been satisfactorily completed, the complete system shall be placed in operation and allowed to run for at least 72 hours. It is recommended that the installation be continuously supervised by a competent person. Check and observe the following features, and adjust if necessary. All operation information shall be recorded hourly in a log book.

- (i) The oil level in the compressor shall be monitored closely during the entire period. The compressor must not be allowed to run short of oil.
- (ii) Maintain sufficient load to keep the plant running during the whole period. This may mean the provision of an artificial load.

- (iii) Superheat setting of the thermostatic expansion valve using the method given in Clause 4.2.3.2.5 (b)(iii).
- (iv) Checks must be carried out under conditions approximating to design conditions (i.e. average or maximum load, but not light load) and with satisfactory condensing pressure.
- (v) Do not alter superheat setting until it is certain that the reset of the system is operating satisfactorily. If incorrect values of superheat are found, gradual adjustment of the control setting (as given in the manufacturer's instructions) and rechecking of the superheat value shall be made.
- (vi) All operating temperatures and pressures (in refrigerant cycle and chilled water and condenser water circuits) are under normal running conditions. Refrigerant flows at sight glasses. Bubbles indicate refrigerant shortage and possible leak.
- (vii) Amperage and voltage readings of all motors and any sparking at commutator or slip rings should be recorded.
- (viii) Check the system for refrigerant leakage. This shall be done at least twice during the running-in period.
- (ix) When these checks have been made and the plant is running satisfactorily and steadily, check the operation and calibration of control and protection devices.
- (x) The operation and control of the refrigeration plant by the primary control device (thermostat, etc.). The actual control of the condition (temperature, etc.) by the device will be checked as given in Clause 4.2.3. and the following procedures should be followed:
 - this operation shall be achieved by a gradual reduction of the cooling load;
 - this shall be done solely so that there is ample time to note any extended sequence of events; and

- when the refrigeration plant has stopped, load can be gradually increased, so as to observe the automatic starting up sequence.
- (xi) During the load changing procedure, the satisfactory operation of the liquid line solenoid valve, compressor capacity control system, unloaded compressor start-up, and automatic pump down, where these facilities are specified, shall be observed.
- (xii) Low pressure cut-out: Close the liquid line shut off valve (isolating valve on liquid receiver or cause the liquid line solenoid valve to close). Isolating valves shall be opened and closed as slowly as possible and then
- the compressor shall reduce pressure in the evaporator;
 - check that the low pressure cut-out operates at the suction pressure recommended;
 - watch the suction gauge carefully, do not allow the suction pressure (particularly with water chillers) to fall more than 0.1 bar below the recommended setting; and
 - open the valve and check the pressure at which compressor cuts in.
- (xiii) High pressure cut-out: Gradually reduce the flow of the condensing medium (by bypassing the condensing water or restricting the air flow to or from the air-cooled condenser). The condenser pressure will rise. Then
- check that the high pressure cut-out operates at the condenser pressure as recommended and set;
 - watch the pressure gauge carefully, do not allow the condenser pressure to rise appreciably above the recommended setting; and
 - slowly restore flow of condensing medium and check the pressure at which compressor cuts in (with manual rest it

will be necessary to depress reset button).

(xiv) Condenser pressure control, where fitted. During this period, if possible, note the operation of condenser pressure control under either naturally occurring low external temperature conditions or where possible simulate the conditions on a multi-compressor plant feeding the whole of the condensing capacity to one machine.

(xv) If evaporator pressure regulating valve is fitted,

- reduce the cooling load, so that suction pressure tends to drop; and
- observe the evaporator pressure (if a special gauge has not been fitted, fit one temporarily at the evaporator on the evaporator side of the valve); this shall not fall below the required value, even though the suction pressure drops to cut-out level.

(xvi) With the assistance of manufacturer's recommendation, check the operation of any other special control or operating devices such as low water temperature control, low water flow control, or hot-gas by-pass circuit controls. Where any device is installed for protection of the plant, care must be exercised when checking so that should the protective device fail to operate, the plant shall stop immediately.

(xvii) Condenser pressure against condenser temperature: If pressure is excessive, this indicates presence of air or other non-condensable gases. Stop the plant, allow the condenser to cool, then purge. Restart the plant, recheck, and re-purge if necessary.

(xviii) All mechanical equipment shall be checked for excess heat, noise and vibration.

(f) First Inspection after Running-In

This cannot be carried out until the plant has been in operation for at least 72 hours. By the end of the

running-in period any improper adjustments or sources of potential troubles shall become apparent.

- (i) Recheck the compressor oil level. If low, wait further 3 or 4 hours to see that returning oil does not restore to the proper level. If level remains low, further lubricating oil should be added to maintain correct level;
 - (ii) Ensure that the compressor crankcase heater is working so that oil level is not high due to refrigerant distilling into the oil;
 - (iii) Remove test gauges and plug tapings;
 - (iv) With compressor stopped, check the compressor shaft seal for refrigerant leakage;
 - (v) Check the alignment and lubrication of compressor motor. Check and tighten as necessary the holding-down bolts;
 - (vi) Check the drive belts for proper tension and alignment; and
 - (vii) Check the sight glass. If there is presence of appreciable moisture, change the dryer.
- (g) Final Inspection after Running-In

This shall be carried out after the system has been in operation for not less than 1 week:

- (i) drain the compressor crankcase and clean the interior with approved cleaner;
- (ii) recharge the compressor with new clean compressor oil of the exact type and grade specified by the manufacturer;
- (iii) tighten bolts in coupling between compressor motor (or adjust belt drive as necessary); and
- (iv) change the dryer element.

4.2.3.3 Centrifugal Compressor System (Including Oil Free Compressor)

The complete plant must have been pressure and leak tested, evacuated and dehydrated, and the system charged with refrigerant and lubricating oil by the specialists from the supplier prior to

running. The charging operation is normally carried out by the specialists from equipment supplier on the Site. In addition, cleanliness, stage of system, mechanical and electrical components must be checked.

On open type centrifugal machine, ensure transmission is lined up in accordance with manufacturer's instructions.

Check that:

- (a) the evaporator and condenser shells are correctly levelled;
- (b) all flanged connections are correctly aligned and tightened, with proper gaskets in place;
- (c) the liquid line and float valve assembly are completed;
- (d) vibration isolation to compressor is provided in accordance with manufacturers' recommendations;
- (e) motor cooling connections are completed;
- (f) the purge unit for negative pressure refrigerant systems, and small-bore accessory piping are completed, including cooling water connections where specified;
- (g) oil pump accessories and connections are installed;
- (h) control gauges and tubing are completed; and
- (i) temperature control bulbs/sensors are correctly located, space between bulb and well is filled and suitable heat conducting fluid, and capillary tubes are free from damage or distortion.

4.2.3.3.1 Pressure and Leakage testing

Refrigeration system working and testing pressures are defined in the manual of the manufacturer.

(a) Factory Assembled Units

These are factory pressure and leak tested, often insulated, and delivered to site with a holding charge of refrigerant /nitrogen.

- (i) Observe pressure gauge readings. If gauges register zero unit may have been damaged in transit and holding charge lost, in that case the whole programme of pressure and leakage testing must be carried out again;
- (ii) If gauge readings are in order then a leak test shall be carried out around all joints.

Alternatively, units may be despatched under vacuum and in this case the manufacturer's recommended procedures should be followed.

(b) Site-assembled Units

Pressure and leakage testing should be carried out on completion of the installation, before the unit and the immediately adjacent pipework connections are insulated, and before condenser or evaporator is finally filled up with water. The following actions shall be taken:

- (i) a cylinder of dry nitrogen and a small amount of refrigerant of a type recommended by the manufacturer shall be used to pressure test the system;
- (ii) the refrigerant recommended by the equipment manufacturer/supplier shall be used for this purpose and also serves as a tracer for leak detection;
- (iii) where the required test pressures exceed the allowable pressures on certain items, remove or isolate these components. Ensure the system is suitably sealed to enable the pressure testing to be carried out;
- (iv) where the purge unit is subjected to a higher operating pressure than the remainder of unit, it shall be isolated and tested separately at a higher pressure;
- (v) charge the purge unit to the desired test pressure with proper type of refrigerant in accordance with the manufacturer's instructions;
- (vi) check the entire purge unit for leaks using a halide torch or electronic leak detector. Tap all joints with a mallet and remove any flux that may be adhering to them;
- (vii) repair any leaks and retest the unit. Leaks must not be repaired while the system is under pressure;
- (viii) on satisfactory completion of test, relieve test pressure (by opening valves in connecting pipework to main unit) and remove charging apparatus;

- (ix) reinstate any items previously removed or isolated and
 - to charge and leak test the entire unit, first connect a cylinder of refrigerant as recommended by the manufacturer to the charging valve; and
 - to charge enough refrigerant into the system to produce a pressure as recommended by the manufacturer for leak test purposes;
- (x) close the charging valve and remove the refrigerant charging apparatus;
- (xi) connect a cylinder of dry nitrogen to the charging valve on the unit and charge to the desired test gauge pressure. Suitable nitrogen injection pressure reducing valve is fitted;
- (xii) close the charging valve and remove the charging equipment;
- (xiii) check all joints for leaks by electronic leak detector, then followed by using a soap solution “bubble” test and
 - pay attention to all gasket joints, bolt heads and nuts, sight glasses, welded joints, parting lines on castings, gauges and gauge connections, relief valves, evaporator and condenser water boxes; and
 - pay attention to the motor terminals of hermetic units; or check the shaft seals on open machines.
- (xiv) repair any leaks found in the system. Leaks must not be repaired while the system is under pressure;
- (xv) when the system is found to be free from leakage, allow it to stand for a minimum of 24 hours under pressure. If no pressure drop occurs (allowing for effect due to changes in ambient temperature) the system is ready for evacuation; and

(xvi) relieve test pressure to atmosphere, reconnect all lines and reinstate all items removed or isolated prior to pressure testing.

4.2.3.3.2 Evacuation and Dehydration

This shall be carried out by specialists assigned by the equipment manufacturer/ supplier.

4.2.3.3.3 Associated Air Systems

Check in accordance with Clause 4.2.3.2.3

4.2.3.3.4 Charging

The procedure to be adopted shall vary according to the make of unit and type of refrigerant and shall be carried out by specialists.

4.2.3.3.5 Setting to Work and Adjusting

(a) Procedures

After satisfactory completion of procedures in Clauses 4.2.3.1 and 4.2.3.3.1 to 4.2.3.3.4, and before operating the centrifugal compressor for the first time, a further visual check shall be carried out on the complete system.

The chilled water and condenser water systems must have been thoroughly checked in accordance with Clauses 4.1.6 and 4.2.1, and be ready for operation. For this section to be carried out completely, some load on the chilled water plant (probably at least 50%) is necessary.

(b) System Check

(i) Controls

The procedures below shall be followed:

- with all electrical supplies isolated, check wire connections for tightness and fuses for correct size;
- with centrifugal compressor motor electrically isolated, check that chilled water pumps, condenser water pumps, cooling tower fans, and centrifugal refrigerant plant oil pump operate in the sequence required, rotate in the proper

direction, and that flow rates and pressures are set to the required levels;

- ensure that centrifugal compressor motor will be “locked-out” if other equipment essential to its operation stops for any reason;
- set each control and safety device in accordance with manufacturer’s instructions, or ensure that factory settings are correct and have not been disturbed. The complete control system shall be checked out generally in accordance with Clause 4.2.3;
- check for satisfactory operation of pilot lights and reset buttons;
- check the settings and the functional operation of the following items as appropriate to system under consideration:
 - pneumatic/electric switches;
 - oil temperature control (this may require check on operation of sump cooling water solenoid valve and sump heater);
 - oil pressure relief valve;
 - oil filter pressure cut-out switch;
 - low pressure oil cut-out switch;
 - high pressure oil cut-out switch;
 - chilled water low temperature cut-out;
 - refrigerant low temperature cut-out; and
 - cooling tower thermostat and condensing water controls.

may also be fitted with :

- time delay relay on inlet vane operator;

- vane closed switch;
- time delay relay on oil pump (to prolong running on shut down cycle);
- timers in main motor starter;
- thrust bearing and transmission bearing high temperature cut-out thermostat (on compressor);
- timer (to limit number of starts per hour) and recycling device;
- motor winding high temperature cut-out switch; and
- flow switches (chilled and/or condenser water).

(ii) Purge Unit (for negative pressure refrigerant i.e. R123)

The procedures below shall be followed:

Compressor purge system

Check:

- oil levels in compressor sump and oil separator sections;
- operation of high pressure control;
- operation of temperature control and purge heater;
- alignment of the motor and compressor shafts, drive belt adjustment, and lubrication of compressor motor bearings in accordance with manufacturer's instructions; and
- that the system isolating valves are in correct positions (open/closed).

Thermal purge system

Check:

- in accordance with manufacturer's instructions and ensure all valves are in correct position (open/closed).

(c) Start-Up

The procedures below shall be followed :

- (i) ensure all electrical switches and starters are in "off" position and supplies are isolated. Replace any fuses or leads removed during Clause 4.2.3.3.5 (b)(i);
- (ii) ensure all water valves are in proper position;
- (iii) place chilled water pump, condenser water pump, cooling tower fan, refrigeration machine oil pump and purge system starters in "auto" position and close isolators;
- (iv) start the chilled water and condenser water pumps and cooling tower fans;
- (v) energise the control circuits;
- (vi) start the oil pump and allow the main compressor to run;
- (vii) check the compressor impeller rotation. If incorrect, stop immediately, electrically isolate, and reverse any two of the three phase connections. Recheck;
- (viii) start the purge system as follows:
 - Compressor type
Energise the purge heater and after 30 minutes, start purge compressor, or in accordance with manufacturer's instructions. The longer in time is better;
 - Thermal type
Start in accordance with manufacturer's instructions;

(d) Shut-Down

The procedures below shall be followed:

- (i) stop the compressor and then the chilled water pumps, condenser water pumps and cooling tower fans in sequence;
- (ii) listen for any unusual sound from compressor or transmission housing during “closed-down” period;
- (iii) check that the operation of oil pump continues until the time delay relay causes it to stop;

(e) Running-In

The procedures below shall be followed:

- (i) restart the plant in accordance with the above Clause;
- (ii) check the oil pressure and temperature;
- (iii) check the operation of refrigerant agitator solenoid valves (where fitted) in relation to vane motor crank angle;
- (iv) adjust the motor overload trip mechanism in accordance with the instructions of the compressor by the manufacturers;

(Caution: Do not allow motor to operate in overloaded condition beyond the time permitted by the manufacturer, typically 60 minutes at 105 per cent of full load amperage).

- (v) adjust low limit relay to manufacturer’s instructions;
- (vi) check for satisfactory operation of low temperature control;
- (vii) check for satisfactory operation of refrigerant low temperature cut-out;
- (viii) check operation of high pressure cut-out (if necessary isolated switch and use metered air supply);
- (ix) take the gauge and other readings and compare them with design figures, typically;

- evaporator pressure;

- condenser pressure (measure water temperature if necessary);
- purge drum pressure;
- oil sump temperature;
- oil level; and
- chilled water and condenser water temperatures.

4.2.3.4 Absorption System

The absorption refrigeration machine shall be factory assembled, though, certain necessary items may be installed on the Site. Prior to running, the unit must be pressure and leak tested, evacuated and charged with primary refrigerant (usually lithium bromide solution) and chemicals.

The charging operations are usually carried out on the Site. In addition, cleanliness, stage of system and mechanical and electrical components must be checked.

Check:

- (a) that the unit is correctly installed and levelled;
- (b) that the chilled water and condenser water circuits are complete and are ready to operate. Water treatment is available if specified;
- (c) that the steam and condensate, or hot water piping system are completed with adequate pressure gauges, thermometers, and test points;
- (d) for steam piping system: pressure relief valve and safety valve are correctly set; trapping arrangements are satisfactory; control valve is correctly installed;
- (e) for hot water piping system: control valve is correctly installed;
- (f) that steam, or hot water, is available at rated pressure/temperature;
- (g) that auxiliary water piping and drains are completed (as may be required for pump motor and cooling during start-up periods);
- (h) that all electrical wiring, starters, motors, and controls are completed;
- (i) that pneumatic controls (where used) are installed, pneumatic piping is completed and tested, air pressure is available;

- (j) that all gauges and thermometers (or test points) are installed on water inlets and outlets to evaporator, absorber and condenser;
- (k) that dry nitrogen and refrigerant are available for pressure and leakage testing (when carried out on the Site);
- (l) that lithium bromide solution and chemical oils are available for charging, together with necessary equipment;
- (m) that for the system to be operated and properly commissioned. It is usually necessary to have at least 75% of the cooling load available;
- (n) in conjunction with the manufacturer's representative, ensure that phase sequence of power supply is checked and that connections are properly made before hermetic pumps are operated (for some types of machines).

4.2.3.4.1 Site Leakage testing

(a) Absorption Unit Shell

- (i) isolate the purge unit (manual valve between purge drum and purge pump);
- (ii) charge a small amount of the recommended refrigerant into the unit through the access valve on concentrator sump;
- (iii) raise the gauge pressure within the unit to test figure (typically 0.75 bar) with dry nitrogen;
- (iv) check for leakage with halide torch or electronic leak detector. In particular, check all welds, joints, float valves and around the hermetic pumps; and
- (v) correct or repair any leaks, and retest as necessary.

(b) Purge System

- (i) ensure gauge unit is isolated;
- (ii) close the gas ballast valve on the purge pump;
- (iii) connect vacuum hose to the purge pump exhaust fitting, place open end of hose in glass container of water and start the pump;

- (iv) purge system is leak free if no bubbles appear in water after about 10 minutes operation. Pay attention to the power supply interruption, otherwise water may be sucked into the system;
- (v) if the result is satisfactory, slightly open the gas ballast valve until bubbles appear in water; and
- (vi) remove test equipment. Purge system is now ready for service.

4.2.3.4.2 Evacuation

This will be carried out by specialists assigned by the equipment manufacturer/supplier.

4.2.3.4.3 Associated Air Systems

Check in accordance with Clause 4.2.3.2.3

4.2.3.4.4 Charging

This will be carried out by specialists assigned by the equipment manufacturer/supplier.

4.2.3.4.5 Setting to Work and Adjusting

(a) Procedures

- (i) after satisfactory completion of procedures in Clauses 4.2.3.1 and 4.2.3.4.1 to 4.2.3.4.4 and before operating the absorption machine for the first time, a further visual check should be carried out on the complete system; and
- (ii) the chilled water and condenser water systems must have been thoroughly checked in accordance with Clauses 4.1.6 and 4.2.1 and be ready for operation. The heating fluid (steam or hot water) circuit must have been similarly checked and be ready for operation.

(b) System Checks

The procedures below should be followed:

- (i) with absorption machine solution pumps electrically isolated;

- (ii) check that chilled water pumps, condenser water pumps and cooling tower fans operate in the sequence required, rotate in the proper direction, and that flow rates and pressures are of the required settings;
- (iii) ensure that solution pumps will be “locked-out” if other equipment essential to their operation stops for any reasons;
- (iv) set each control and safety device in accordance with manufacturer’s instructions or ensure that factory settings are correct and have not been disturbed. The complete control system should be checked out generally in accordance with Clause 4.3.3;
- (v) check the settings and the functional operation (by raising and lowering the temperature of water at sensing element if necessary) of the following items as appropriate to the system under consideration;
 - load controller, usually chilled water thermostat;
 - operation of automatic control valve on heating medium. Ensure medium is at the desired temperature and pressure;
 - pneumatic/electric switches (on pneumatic systems) and set in accordance with manufacturer’s instructions;
 - high temperature control, where fitted; (Typically factory set to cut out at 24 °C and cut-in at 18°C refrigerant water temperature.);
 - time delay relay for high temperature control;
 - low temperature control; (Typically factory set to cut-out at 2°C and cut-in at 6°C refrigerant water temperature.);
 - chilled water flow switch (where fitted);

- condenser water flow switch (where fitted);
- cooling tower thermostat. Ensure raising and lowering of set point can start and stop of the tower fans;
- condensing water thermostat;
- operation of condensing water control valve;
- setting of motor temperature control protectors;
- some types of machine require refrigerant water for lubrication of refrigerant and solution pumps. On these machines the refrigerant sump is dry at start-up and must be filled with distilled water in accordance with the manufacturer's instructions. Air must not be allowed to enter the system; and
- check operation of float switch controlling minimum operating level of refrigerant (after filling of sump where applicable).

(c) Start-Up

- (i) ensure all electrical switches and starters are in 'off' position and supplies are isolated. Replace any fuses removed;
- (ii) place chilled water pump, condenser water pump and cooling tower fan starters in 'auto' position and then close the isolators;
- (iii) ensure all water valves are in proper position;
- (iv) open the heating fluid isolating valve;
- (v) start the chilled water and condenser water pumps, and cooling tower fans; and
- (vi) start the absorption refrigeration machine and place solution pumps in operation (i.e. evaporator, concentrator and absorber pumps).

(d) Shut-Down

The sequence of operation of the 'dilution' or shut-down cycle must be checked. This dilution cycle normally allows the unit pumps to operate under the control of a time delay relay:

- (i) stop the absorption refrigeration machine. The condenser pumps and the cooling tower fans should stop immediately and the heating control valve should close; and
- (ii) check that the time delay relay permits the chilled water pumps and the solution pumps to continue operation for the period of time specified by the manufacturer (typically about 7 minutes).

(e) Running-in

- (i) with purge unit operating allow the system to operate for approximately 8 hours and at the same time observe the performance and make any necessary adjustments. Ensure purge unit operates satisfactorily;
- (ii) after approximately 8 hours, stop the unit, then isolate, clean and replace all strainers. Return isolating valves to normal position; and
- (iii) if unit operation is satisfactory, arrange for final insulation of those parts normally left incomplete until system has been commissioned.

4.2.3.5 Screw Compressor System

The procedure described is for a factory assembled screw compressor water chiller, which has been pressure and leak tested, evacuated and dehydrated at the manufacturer's works, and transported to site as a complete assembly, with operating charges of refrigerant and lubricating oil.

Commissioning should be carried out in accordance with the manufacturer's instructions.

(a) Check:

- (i) that the unit refrigerant and oil charges are intact. If unsatisfactory, arrange for checks and repair leaks; pressure test, dehydrate and recharge by the manufacturer;

- (ii) that the unit is installed in accordance with manufacturer's recommendations and designer's specification;
- (iii) that the unit is correctly levelled;
- (iv) that vibration isolators (where specified) are provided in accordance with designer's instructions;

4.2.3.5.1 Pressure and Leakage Testing

- (a) pressure and leakage testing should be carried out on completion of the Installations, before the unit and the immediately adjacent pipework connections are insulated, and before the condenser or evaporator is finally filled with water.
- (b) a cylinder of dry nitrogen and a small amount of refrigerant (recommended by the manufacturer) should be used to pressure test the system and the refrigerant also serves as a tracer for leak detection purpose:
 - (i) charge a small amount of refrigerant into the low side of the system, using convenient valve to achieve a gauge pressure of about 2.0 bar. (It is essential to use low side charging where compressor discharge line is fitted with check valve.);
 - (ii) close the charging valve and remove the charging apparatus;
 - (iii) carry out preliminary leak test using halide torch or electronic leak detector;
 - (iv) connect a cylinder of dry nitrogen to the charging valve and charge to the desired test gauge pressure recommended by the manufacturer/supplier;
 - (v) close the charging valve and remove the charging apparatus;
 - (vi) thoroughly re-check the entire system for leaks;
 - (vii) repair any leaks and retest the system. Leaks must not be repaired while the system is under pressure;

- (viii) when the system is found to be leak-free, allow to stand for a minimum of 24 hours under pressure. If no pressure drop occurs (allowing for effects due to changes in ambient temperature), the system is ready for evacuation; and
- (ix) depressurise the system to atmospheric pressure (where discharge check valve is fitted, the high side after the check valve must be separately depressurised).

4.2.3.5.2 Evacuation and Dehydration

This will be carried out by specialists assigned by the equipment manufacturer/supplier.

4.2.3.5.3 Associated Air Systems

Check in accordance with Clause 4.2.3.2.3.

4.2.3.5.4 Charging of Refrigerant

This will be carried out by specialists assigned by the equipment manufacturer/supplier.

4.2.3.5.5 Setting to Work and Adjusting

(a) Procedure

After satisfactory completion of procedures in Sections 4.2.3.1 and 4.2.3.5.1 to 4.2.3.5.4, and before operating the compressor continuously for the first time, a further visual check should be carried out on the complete system.

(b) System Checks

- (i) with compressor motor power circuit electrically isolated, set all refrigeration controls in accordance with PBSE's instructions, or ensure that factory settings are correct and have not been disturbed. All safety controls should be put through their complete cycle of operation;
- (ii) as a guide, typical controls are listed below. Control settings should be in accordance with the design specifications; safety settings should be based on manufacturers' recommendations;

- pressure switches;

- high pressure cut-out;
- low pressure pump down;
- low pressure cut-out;
- low pressure unload;
- high pressure oil cut-out;
- oil failure switch;
- temperature switches;
- freeze-up;
- low water temperature;
- oil sump temperature heater control;
- low oil sump temperature heater control;
- timing relays;
- oil failure relay;
- oil pump coast-down relay;
- compressor loading time delay;
- oil circulating time delay;
- anti-recycling relay;
- flow switches;
- set to cut-in and cut-out at flow rates recommended by manufacturer;
- set temperature/load controller in accordance with manufacturer's recommendation and Clause 4.3.3 (preliminary settings only);
- other adjustments;
- certain types and sizes of screw machine may have adjustments relating to hydraulic unloader cams, which should be set by manufacturer's representative;

- the hydraulic unloader level time should be set by manufacturer's representative; and

- this includes:

Fast unload maximum to minimum load;
Minimum load to maximum load; and
maximum load to minimum load.

- (iii) with compressor power circuit energised, check:

- the oil pump for correct rotation;
- the compressor for correct rotation (momentary start). Do not let the compressor attain the full running speed, since if running backwards, high speed operation may cause damage; and
- checks should be carried out strictly in accordance with manufacturer's recommendations.

(c) Start-Up

Manual sequence

- (i) switch on heater in oil sump and wait until recommended oil temperature (typically 43°C) is attained;

Note: Manufacturer may recommend warm-up period of 24 hours with compressor power circuit isolated

- (ii) energise compressor control circuits;
- (iii) start those items of equipment required to operate by sequence interlock before compressor is started. Ensure compressor will "lock-out" if items essential to its operation stop for any reasons. Check all safety controls and reset;
- (iv) restore power to compressor power circuits, and start the compressor in accordance with manufacturer's instructions, ensuring oil pump operative, compressor unloading slide valve moves to fully unloaded position, and other items working correctly by observation of pilot lights;

- (v) if oil pressure does not reach the required pressure the system will automatically shut down (in approximately 5 seconds). Controls must be reset and/or fault rectified before proceeding;
- (vi) with oil pump operating and correct pressure available, the compressor will be fully unloaded after the oil circulating time delay;
- (vii) check for satisfactory operation of all pilot lights. Ensure items such as hot gas injection solenoid valve (when fitted), small (or single) expansion valve and side oil injection solenoids are operating correctly;
- (viii) on completion of warm-up cycle (2 minutes loading time delay) check that the main oil injection solenoid valve and the temperature/load controller are activated, and fast unload solenoid valve is de-energised;
- (ix) check the compressor loads as required and pilot light is operating when loading. Based on the unit with dual expansion valves, ensure the large expansion valve operates as loading exceeds 33 per cent;
- (x) check and adjust superheat settings to design requirements (typically within range 10 to 14°C);
- (xi) check the oil gauge pressure and level at 100 per cent capacity (typical 2.0 bar with level to bottom of upper sight glass in sump); and
- (xii) set the temperature/load controller in accordance with designer's brief (final settings).

(d) Shut-Down

Automatic Sequence

- (i) check that the large expansion valve (if provided) closes at approximately 25% capacity (may be activated by cam switch in relation to unloader slide valve travel);
- (ii) when the temperature of chilled water reaches the setting of low temperature

switch check that shut-down (which normally takes place below 10% load) occurs as follows:

- small expansion valve (if provided) is de-energised;
- compressor shuts down at required suction pressure (typically a gauge pressure of 5.4 bar);
- main and side oil injection valves are de-energised; and
- temperature/load controller is locked out and all appropriate pilot lights go out;
- oil re-circulating pump stops after 10 seconds (held in by oil pump coast down relay) to complete automatic shut-down; and
- ensure that the anti-recycle relay prevents compressor from restarting until preset time (15 minutes minimum) after low water temperature switch cuts back in.

(e) Running-in

Note: These checks should be carried out after approximately 1000 hours of operation:

- (i) change the refrigerant filter dryer(s) if moisture shows “wet” or if the desired pressure differential exceeds typically a gauge pressure of 0.27 bar;
- (ii) take oil sample and submit to compressor manufacturer for analysis; and
- (iii) check cam settings, superheat, sub-cooling temperature and the unloader speed.

4.2.3.6 Cooling Tower

General criteria for setting up the ground rules for proper T&C of cooling towers are as described below.

4.2.3.6.1 Conditions for T&C

There are certain conditions that require to be fulfilled before T&C can commence. Ensure that:

- (a) the water system serving the tower has been thoroughly cleaned, preliminary checks and setting to work and balancing have been carried out in accordance with Clauses 4.1.6 and 4.2.1;
- (b) the fan serving the cooling tower has been set to work in accordance with Clauses 4.1.7 and 4.2.2 noting any permanent obstruction and removing all foreign obstructions;
- (c) the interior fills of the tower are properly cleaned and free from foreign materials such as scale, algae or fur;
- (d) the water level in the tower basin is maintained at the proper level, making sure by visual check of the basin sump that the centrifugal action during full flow does not cause any entrainment of air which may cause pump cavitation;
- (e) all valves except balancing valves in the water system are in full open position; and
- (f) provisions for facilities to determine make-up and blowdown water flow rates are available.

4.2.3.6.2 Test Method

The actual test method consists of the following steps :-

- (a) determine volume of water in the tower, volume of make-up water and volume of blowdown water;
- (b) record temperature of make-up water;
- (c) measure the volume and temperature of make-up water at the point of entry to the system;
- (d) measure the volume and temperature of blowdown water at the point of discharge from system;
- (e) measure inlet and outlet dry and wet bulb temperatures;
- (f) use entering & leaving wet bulb temperatures to determine the tower performance against design;
- (g) use entering and leaving dry and wet bulb temperatures to determine the rate of evaporation involved;

- (h) measure wet and dry bulb temperatures between 1 and 1.5 metre from the tower on all sides. These readings should be taken half-way between the base and the top of the inlet louver at not more than 1.5 metre spacing horizontally and averaged out;
- (i) note any unusual inlet conditions, wind velocity and wind direction at the time of test;
- (j) take readings continually with a minimum of time lapse between readings; and
- (k) if the first test indicates a tower deficiency, perform 2 additional tests to verify the original readings.

4.2.3.7 Automatic T&C

Automatic T&C procedures of refrigeration plants described in this section are only applicable to a refrigeration system with CCMS or otherwise specified in the Particular Specification and are mainly on conditional and performance basis as follows:

- (a) the recommended procedures state the ways to undertake automatic testing, monitoring and commissioning of the refrigeration system in achieving the designed functions and performance specified;
- (b) these procedures shall not be treated as the starting-up T&C for individual refrigeration machines such as chillers, pumps, cooling towers, etc., which require to be closely monitored, aligned, adjusted, tuned and balanced by skilled and experience technicians in accordance with the manufacturer's/supplier's recommendations for smooth operation without any initial damages; and
- (c) the chiller & CCMS shall have a high level integration.

4.2.3.7.1 Automatic Scanning and Logging of Status and Conditions of Refrigeration Plants

Below is a list of the recommended output signals to be linked to the CCMS so that the conditions of the refrigeration plants can be closely monitored. Exact details and point schedules shall refer to the Particular Specification and Contract Drawings.

- (a) entering and leaving chilled water temperatures of each chiller;
- (b) entering and leaving condenser water temperatures of each chiller;

- (c) condenser refrigerant temperature and pressure of each chiller;
- (d) evaporator refrigerant temperature and pressure of each chiller;
- (e) oil supply temperature and pressure of each chiller;
- (f) entering and leaving condensing water temperature of each cooling tower (for water cooled system only);
- (g) entering and leaving hot water temperature of each heat recovery unit (for refrigeration plant with heat reclaim unit);
- (h) on /off / fault status of each chiller water / condensing water / chemical dosing pumps;
- (i) on / off status of each chilled water / condensing water / refrigerant motorised on / off valves;
- (j) fault signal(s) from each chiller, cooling tower, variable speed controller and other refrigeration machines;
- (k) electrical operating voltage and current of each chiller / chilled water pump / condensing water pump / cooling tower fan; and
- (l) other signals stipulated in the Particular Specification, Contract Drawings or recommended by the manufacturer / supplier of that particular refrigeration machine.

4.2.3.7.2 Automatic Configuration of Optimum Sequencing of Chillers

For a refrigeration system requesting automatic optimum sequencing control of chillers, an energy programme developed in the CCMS shall be able to carry out the following automatic procedures in working out the optimum chiller-sequencing configurations. The full load and partial load energy performance of each chiller (provided by the following automatic testing of chiller's performance) shall be input to the CCMS and the energy programme shall then work out the most energy efficient chiller combination under different load demand conditions.

Automatic testing of chiller' s performance

- (a) for constant condenser air (air-cooled chiller)/water (water-cooled chiller) entering temperature, % full load (input) against % full load capacity table/chart shall be provided by the manufacturer or supplier. Database in software format shall also be available for performance monitoring and testing at both partial and full load conditions. In order to continuously monitor and compare the actual chiller performance, real-time measurements of the condenser air/water entering temperature, leaving chilled water temperature, entering chilled water temperature and mass flow rate of chilled water are therefore required;
- (b) for continuous measurement of condenser air/water entering temperature, leaving chilled water temperature (T1), entering chilled water temperature (Te), mass flow rate (m), and specific heat capacity (Cw) the following instruments shall be permanently installed as shown in Figure 4.2.3.7.2 below for automatic logging of their instant values. The accuracy for temperature sensors and flow meters shall be at least 0.5% with the full load.

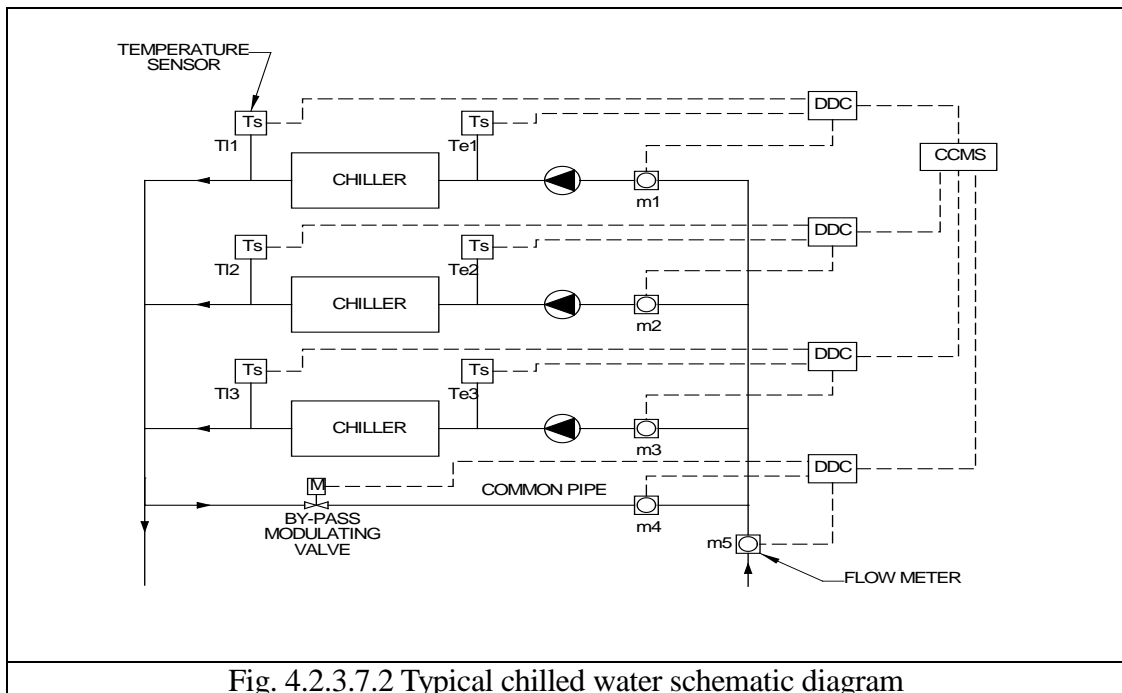

Fig. 4.2.3.7.2 Typical chilled water schematic diagram

All output data of the instruments mentioned above together (input) (manufacturer shall normally provide built-in measurement instruments to measure the input power). These instant values shall be transferred to CCMS via DDCs for calculation of the cooling capacity using the equation (Cooling capacity of the chiller = m

$C_w (T_e - T_1)$) and then used to compare with the manufacturer's chiller performance table/curve/database at the same condenser air/water entering temperature. The real-time chiller's performance and comparison result can be read directly from the monitor or printed-outs. For chillers without built-in % full load (input) against % full load capacity database, separate instrument for measurement of % full load (input) shall be provided;

- (c) for full load performance test, the following procedures are used:
 - (i) for parallel chillers as shown in Fig.4.2.3.7.2, except the branch containing the chiller to be tested, all other chillers should be decoupled and isolated from the chiller system by shutting down the chillers and closing the corresponding motorised valves at the common pipe i.e. the (by-pass de-coupler) under the control of the CCMS;
 - (ii) at the same time, the testing chiller will sense the substantial temperature difference between the entering and leaving chilled water. The compressors of the testing chiller will cut-in one by one until the testing chiller reaches the full load condition; and
 - (iii) from the data obtained from the instruments mentioned above via DDC, the full load cooling capacity of the chiller will be calculated by the CCMS using the equation (Cooling capacity of the chiller = $m C_w (T_e - T_1)$) at that condenser air/water entering temperature. Those results are then compared with the database (supplied by the chiller manufacturer) for full load cooling capacity of the chiller at the same condenser air/water entering temperature. The real-time chiller's full load performance and comparison result can be read directly from the monitor or print-outs.

4.2.3.7.3 Automatic Performance Data Logging

If so specified in the Particular Specification or Contract Drawings, an energy programme shall be so designed in the CCMS that a continuous performance monitoring of the refrigeration plants can be undertaken automatically by the CCMS.

- (a) for the implementation of this test, energy meters shall be installed to measure the actual chilled water energy output and the actual power consumption of each chiller and its associated chilled water pump and condenser water pump;
- (b) the chilled water energy output will then be plotted against the actual power consumption under different load profile in order to work out performance curves for each chiller;
- (c) for a full range of performance data, the test should be carried out for a sufficient long period of time (say 12 months or within the whole Maintenance Period) such that data can be obtained from each chiller from its full load condition to the lowest partial load condition; and
- (d) the information obtained in the test will form an important database in the CCMS to monitor the conditions of the refrigeration plants and hence the arrangement and scheduling of maintenance works after the Maintenance Period.

4.2.3.7.4 Testing of Safety Devices for Refrigeration Plants

For testing of safety devices in chillers such as high pressure cut, low pressure cut, no flow trip, high oil temperature / pressure cut, etc., the T&C works can be carried out manually or if specified by using a simulator provided by the manufacturer / supplier and undertaken by a skilled and experience personnel assigned by the manufacturer / supplier. Every necessary step shall be taken to prevent the refrigeration machines from being damaged accidentally during the tests.

4.3 Other Relevant Tests and Inspections

4.3.1 Indoor Air Quality (IAQ)

Before completion of the Installations, the A/C Contractor shall carry out testing and commissioning of IAQ equipment and system to the satisfaction of the Supervising Officer or to meet the requirements as stated in the Particular Specification.

Testing and commissioning of IAQ installation shall be undertaken by the A/C Contractor's own competent specialist staff or by a competent independent commissioning specialist nominated by and acting for the A/C Contractor and approved by the Supervising Officer. The option chosen shall be declared by the A/C Contractor in the Tender Document.

4.3.1.1 IAQ Parameters

Detailed requirement relating to IAQ shall be under Part D of the General Specification. IAQ parameters and their level of control are specified in the Particular Specification. The 12 parameters are specified, i.e. 3 physical parameters (e.g. temperature, relative humidity, and air movement), 8 chemical parameters (e.g. carbon dioxide (CO₂), carbon monoxide (CO), nitrogen dioxide (NO₂), ozone (O₃), formaldehyde (HCHO), total volatile organic compounds (TVOC), respirable suspended particulates (RSP), and radon (Rn), and 1 biological parameter (e.g. airborne bacteria).

All IAQ parameters shall be measured by calibrated real-time monitors with data logging except the following:

- (a) airborne bacteria colony count; and
- (b) HCHO and O₃ may use passive sampling methods but real-time monitoring is still preferred to passive sampling methods.

4.3.1.2 General Commissioning Requirements

Systems shall be properly adjusted and commissioned to ensure that the equipment achieve the designed airflow rates. The following general requirements shall be met before actual testing and commissioning of IAQ installation are carried out.

- (a) Plant rooms are free of construction waste and debris;
- (b) Access doors to plant rooms are fitted and lockable;
- (c) All builder's works associated with the IAQ systems must be completed and painted with dust preventing compound;
- (d) All ceiling works are completed;
- (e) All dust generating activities by other trades are completed and all areas thoroughly cleaned to prevent ingress of building dust and debris into the return air or fresh air intake systems;
- (f) Air intake screens and louvres are unobstructed and clean;
- (g) Fan and other equipment chambers are clean and free of construction debris;
- (h) Fans are checked for proper operation;
- (i) Floor gullies and drainage traps are clear and operational;
- (j) All condensate drains and trays are clear and water can be drained away satisfactorily;

- (k) Dampers are clean;
- (l) Ducting and other air passage ways are clean;
- (m) All outside air, return air and spill air dampers are operative;
- (n) All volume control dampers are fitted and are at appropriate opening positions;
- (o) Ductwork systems are cleaned by purging of the supply air fan, or by robot duct cleaning recommended by the ductwork cleaning specialist;
- (p) All VAV and CAV terminals are installed, together with grilles and diffusers;
- (q) All filter media are installed; and
- (r) Air conditioning systems and the building indoor area are purged to the standard acceptable by the Supervising Officer.

4.3.1.3 T&C Requirements

After the general commissioning requirements have been verified by inspection, testing and commissioning of the following IAQ equipment and systems shall then be carried out in accordance with the relevant BSB T&C Procedures.

- (a) All air handling equipment : Fans, AHUs, FCUs, water scrubbers, Terminal Air Control devices, grilles and diffusers.
- (b) Air cleaning equipment : All pre-filters, main filters, high efficiency filters and chemical filters, UV lighting and activated oxygen air purifier
- (c) All ductwork and accessories : All ductwork, hoods and dampers.

T&C procedures shall be carried out by licensed personnel as shown in Section D10 of the General Specification to adjust and regulate the system and equipment so as to achieve the IAQ parameters as shown in Section D3 of the General Specification.

The IAQ T&C shall be in-charged by a qualified personnel with qualifications indicated in Section D11 of the General Specification.

4.3.1.4 IAQ Assessment and Methodologies

IAQ assessment shall be performed as the last part of the testing and commissioning process upon completion of the ACMV

installation. Further assessments shall also be done 6 months after the building has been occupied and at 2 months before the Expiry of the Maintenance Period is certified, i.e.,

- (a) First Assessment : After testing & commissioning
- (b) Second Assessment : 6 months after occupation of building or substantial completion
- (c) Third Assessment : Expiry of Maintenance Period

IAQ compliance shall be proved by results of measurements. In addition, an end user satisfaction survey shall be conducted before Expiry of the Maintenance Period.

4.3.1.5 IAQ Measurement

For measuring IAQ compliance, assessment shall be carried out by either the real-time monitoring method or the integrated sampling method. Real-time monitoring shall be used for detection of pollutant sources and provide information on variation of pollutant levels throughout the day. The integrated sampling method shall be carried out by taking samples of a particular pollutant over an 8-hour basis to obtain the total exposure level data. If it is not practicable to have 8-hour samples, short-term sampling to cover the worst scenarios shall be considered subject to approval of the Supervising Officer. All measurements shall be conducted with the use of calibrated instruments and equipment, standards and reference materials with traceability to international or national standards.

- (a) IAQ Measurement using Real-time Monitors;
(see Reference no. 25, 27 of Annex II & 1 of Annex V)
- (b) IAQ Measurement using Passive Samplers; and
(see Reference no. 25 & 28 of Annex II)
- (c) IAQ Measurement using Air-borne Bacteria.
(see Reference no. 25 and 29 of Annex II)

4.3.1.6 Sampling Method

The sample method, location of measuring & monitoring IAQ parameters and measurement method of IAQ parameters shall refer to Part D and as detailed in the Particular Specification requirement.

A walkthrough inspection shall be carried out to identify any inadvertent faults rendering the premises failed to attain the IAQ Objectives, a checklist is provided at Section 25 of Annex II.

Proper sampling positions shall be determined during the walkthrough inspection and mark the positions on the building layout plans. The guidelines for the minimum number of sampling points required are as follows:

Total floor area to be tested (served by MVAC system) (m²)	Minimum Number of Sampling Points
< 3,000	1 per 500 m ²
3,000 to < 5,000	8
5,000 to < 10,000	12
10,000 to < 15,000	15
15,000 to < 20,000	18
20,000 to < 30,000	21
≥ 30,000	1 per 1,200 m ²

However, the qualified examiner should exercise his/her professional judgements to take additional samples if he/she considers necessary.

All air samples shall be collected at 1.0 - 1.2 m above the floor level.

Use real-time monitors to sample the levels of IAQ parameters at a minimum 25% of sampling positions, each position for 5 minutes. Check if they can meet the prescribed control levels. If yes, carry out IAQ measurements.

4.3.1.7 IAQ Measurement using Real-time Monitors

- (a) real time monitors shall be incorporated with data logging facilities. The logged data shall be stored in memory of the monitors and then downloadable to a personal computer for data handling and calculation of time average. The measurement principles of the monitors are provided at Reference no. 1 of Annex V. Alternative measurement principles shall be allowed subjected to the approval of the PBSE;
- (b) except air velocity, the measurement time at each sampling position shall be of minimum 8 hours and covering the whole normal operation hour of the building, at least one reading should be taken every 5 minutes. Shorter sampling time shall be allowed subject to the approval of the PBSE;
- (c) before sampling, a unique identification code should be assigned to each sample collected. These identification codes will indicate the IAQ parameter, the sampling location, and whether the sample is a primary or duplicate sample. In addition to labelling, documentation of sampling equipment, pump airflow rates, start/stop times, sampling conditions,

names of technicians, and other appropriate sampling collection information are also necessary;

- (d) turn on the real-time monitor, check correctness of operation parameters (e.g. mode, logging interval, etc.), and then allow the monitor to log data;
- (e) after logging data for the required sampling period, download the data to computer. Ignore the readings of the initial 10 minutes, and then obtain the highest value of 8-hour average;
- (f) sample the outdoor air condition in parallel with the sampling of the indoor condition, the minimum sample of outdoor shall be 4 number 5-minutes samples taken at 4 time slots distributed within an 8-hour sampling period;
- (g) report and record the results, a record form is provided at Section 27 of Annex II; and
- (h) since the air velocity usually will not fluctuate with time, therefore a short sampling time shall be allowed and to be determined by the qualified examiner.

4.3.1.8 IAQ Measurement using Passive Samplers

- (a) before sampling, a unique identification code should be assigned to each sample collected. These identification codes shall indicate the IAQ parameter, the sampling location, and whether the sample is a primary or duplicate sample. In addition to labelling, documentation of sampling equipment, pump airflow rates, start/stop times, sampling conditions, names of technicians, and other appropriate sample collection information are also necessary;
- (b) the sampling time at each sampling position shall be of minimum 24 hours and covering a normal operation day of the building;
- (c) take a 24-hour sample of the outdoor condition in parallel with the sampling of the indoor condition;
- (d) send the samples to the laboratory for analysis within 5 days. Before analysis, the sampling tubes / filters / bags / canister should be treated and stored as per manufacturers' recommendations. The laboratory results should be signed by an approved signatory; and
- (e) report and record the results, a record form is provided at Section 28 of Annex II.

4.3.1.9 IAQ measurement of Air-borne Bacteria

- (a) before sampling, a unique identification code should be assigned to each sample collected. These identification codes shall indicate the sampling location, and whether the sample is a primary or duplicate sample. In addition to labelling, pump airflow rates, start/stop times, sampling conditions, names of technician, and other appropriate sample collection information are also necessary;
- (b) at each sampling position collect 5-minute samples using Andersen multi-hole impactor samplers with Tryptic soy agar plates at 4 time-slot evenly distributed within an 8-hour sampling period covering periods of highest number of occupancy of a normal operation day;
- (c) collect 5-minute samples of outdoor air at 4 time-slots in parallel with sampling of indoor air;
- (d) send the plates for incubation in less than 24 hours. Incubate the plates at 30°C for 48 hours, and then perform bacterial count. Standard aseptic techniques should be practised throughout the whole process; and
- (e) report and record the results, a record form is provided at Section 29 of Annex II.

4.3.1.10 10% of the integrated samples shall be performed for quality control including duplicate samples, and field blanks.

4.3.1.11 Report the T&C Result of IAQ measurement. A report form is provided at Section 26 of Annex II.

4.3.2 Energy Efficiency Equipment & Systems

The A/C Contractor shall demonstrate by carrying out T&C that the installed air-conditioning and ventilation equipment and system can satisfactorily perform to the requirements on energy efficiency and energy conservation as stipulated in Part E of the General Specification and the Code of Practice for Energy Efficiency of Building Services Installation issued by the Electrical and Mechanical Services Department (EMSD), hereinafter referred to as the “Building Energy Code” or “BEC”.

T&C should be properly carried out before the handover of projects in order to verify that the energy efficiency performance of the following equipment and system, but not limited to, based on technical documents and calculations submitted by the A/C Contractor, can be adequately achieved.

- (a) minimum coefficient of performance of major air-conditioning and ventilation equipment;
- (b) minimum working efficiency of fans, pumps and motors;
- (c) maximum amount of system energy reclaimed; and

- (d) optimum working performance of motion detecting sensing device, enthalpy control device of free cooling, heat pipe installation, solar heating installation, dehumidifiers and outdoor air pre-conditioners.

Tests for evaluating the energy efficiency performance of equipment would be classified into factory test and field test.

- (a) factory test on equipment should be conducted according to the recognised testing standards such as AHRI, ISO, BS EN and so on. Certificates should be issued in order to demonstrate that the technical requirements on energy efficiency as laid down in the Particular Specification are being complied with satisfactorily;
- (b) field test should only be conducted after a set of working details agreed between the A/C Contractor and PBSE. Full set of calibrated instruments should be provided for taking record on design temperature, volumetric and mass flowrate and pressure of air and water at relevant locations, air relative humidity, equipment operating current and voltage and overall power input to the air-conditioning and mechanical ventilation installations (ACMV);
- (c) before the commencement of actual T&C works, the relevant forms specified by the EMSD under the Buildings Energy Efficiency Ordinance should be updated and submitted;
- (d) factory endorsed T&C guidelines for illustrating the compliance of energy efficiency performance requirement should be submitted for checking and agreement;
- (e) calibration certificates of instruments to be used in T&C should be submitted for checking;
- (f) initial visual inspection of the installed air conditioning and ventilation equipment and system shall be carried out;
- (g) if the actual site condition could not allow full load for system testing, a simulated load shall be agreed and generated for testing;
- (h) run in the installed air conditioning and ventilation equipment and system for a short period of time before it becomes steady;
- (i) monitor the steady state system performance;
- (j) measure relevant system performance parameters such as air and water temperature, flowrate, pressure, relative humidity, on/off position of dampers and valves and so on. Based on those measured data and valid scientific equations to verify if the attained energy efficiency performance of the equipment and system is acceptable according to the Particular Specification;
- (k) results of T&C works should be properly documented and certified by the A/C Contractor and PBSE; and

- (l) post-occupation energy efficiency and consumption audit has to be held before the issuance of Maintenance Certificate for deciding on whether there is any adjustment and correction to the system operation logic to be made in order to maximise the working efficiency of the system.

4.3.3 Control Systems

The T&C of CCMS and Building Automation System (BAS) should be carried out by specialists. Control systems as defined herein relate to 'on the plant' control systems, including pressure/temperature sensing points, motorised valves, dampers, etc. with which the CCMS/BAS may interface.

It is essential that all wirings within the control panel should be checked to avoid any loose connections and to ensure correct terminations in compliance with wiring diagrams. In addition, it is also assured that functional checks to ensure that all interlocking and sequencing have been carried out in accordance with the requirements and specifications. It is also critical that the procedures described elsewhere relating to the regulation of air, water, refrigeration systems and any other connected equipment/systems have been carried out prior to commissioning the control system.

Generally, the commissioning procedure shall comply with that set out in the CIBSE Commissioning Code "C" - Automatic Control.

4.3.3.1 Automatic Control System

4.3.3.1.1 Off Site Preparatory Work

Positions for all space thermostats are provisionally shown on the Contract Drawings. The exact final locations shall be selected to give maximum coverage of each space by the control system. The location shall be proposed by the A/C Contractor in the installation drawings and shall be approved by the Supervising Officer before installation of the conduit/box and thermostat.

The A/C Contractor shall prepare and submit the following document and drawing to the PBSE for approval before carrying out T&C work for the Automatic Control System. The document and drawing shall include but not limit to the followings:

- (a) list of systems, plants and equipment to be carried out T&C;
- (b) list of systems, plants and equipment to be interfaced with the CCMS and BAS if any;
- (c) schematic and control wiring diagrams of Automatic Control System;

- (d) location and quantity of sensing, monitoring and control equipment;
- (e) detailed system description for Automatic Control System;
- (f) logic diagrams for Automatic Control System;
- (g) list of tools and equipment for on the Site T&C;
- (h) calibration certificates of tools and equipment for on the Site T&C; and
- (i) form of T&C checklist (refer to Annex II).

4.3.3.1.2 On the Site T&C Works

(a) Preliminary Checks

This section is common to all types of system. Before attempting to set up automatic controls, it should be ascertained that the following requirements are satisfied;

- (i) all electrical supplies are isolated;
- (ii) all control components are installed in accordance with specified requirements and manufacturers' instructions, e.g., that control valves are correctly positioned and ported and that temperature and humidity elements suit the temperature ranges so involved;
- (iii) all safety devices including circuit interlocks and cut-out shall be correctly inserted into the overall operational plan and will effectively carry out the purpose intended;
- (iv) all sensing elements are located in a position which will give good representation of the controlled variable and are not subject to extraneous influence;
- (v) measuring instruments have been calibrated against certified standards;
- (vi) After installation of all the instruments and connecting leads and sampling points, the commissioning engineers shall check the installation and adjustment of the instruments to ensure they are in proper working order. Calibration charts shall be

provided together with the test certificates. The A/C Contractor shall provide records of settings / pressure-levels / positions of actuators, limits, etc.;

- (vii) As far as practical, the A/C Contractor shall demonstrate by simulation of fault conditions, the adequacy of the interlocking alarm circuits' and
- (viii) Functional tests shall be carried out for equipment inter-related with fire services and CCMS control.

(b) Operating Checks

Check:

- (i) that at full rated flow of the controlled media, the pump and fan pressures are within design tolerances immediately prior to setting-up;
- (ii) that the input temperature of the controlled media and the pressure at the input of the controlled device at full design flow condition are each within specified design limits and that the pressure difference across the device comply to design requirements;

Note: In the case of variable fluid flow the pressure available at any particular controlled device will tend to vary in relation to demands at other points of regulation within the system. There will also be some variations of the temperature of fluid available at the inlet of the device particularly at low-flow condition; and

Checks must be made to ensure that at any point in the system the fluid to be controlled is not only available within the specified limits of temperature and pressure but that the controlled device continues to provide the degree of control required throughout the range of variations in flow and pressure to which the system may be subjected;

- (iii) that the movement of the controlled device matches with the travel of the actuator. For example, examine the damper-actuator assemblies.

(c) Electricity Supply and Wirings

The following checks are to be made before switching on the electricity supply:

- (i) that the wiring has been installed to the required standards and regulations and is in accordance with manufacturers' requirements. Special care should be taken to ensure that the cable possesses suitable physical and electrical characteristics and that earthing suits the regulations of the equipment;
- (ii) that all connections are in accordance with the relevant wiring diagrams supplied; and
- (iii) that the electrical supply at the point of distribution for the control system is correct and that suitably rated fuse is available.

(d) Connection to Electrical Supply

Switches for the electrical supply is provided.

4.3.3.1.3 Electrical and Electronic Control Systems

(a) Check-out, Calibration and Setting-up Procedures

The procedure applies main component parts of the system as follows:

- (i) valves, dampers and other actuators; and
- (ii) controllers and detectors.

(b) Actuating Units

Check:

- (i) that the actuator has the correct movement so that it will give the required travel of the final control device;
- (ii) that any linkage adjustments for rotation lift or close-off have been suitably set;
- (iii) that in the case of spring return motor is fitted, the position assumes, upon interruption, the power supply is correct;

- (iv) that all actions intended to succeed an interruption of power, and the subsequent reinstatement, are properly followed; and
- (v) that throughout the procedures there are smooth and regular movement of the actuating motor and regulator.

Note: In the case of valve control, it calls for attention to gland packings and in the case of dampers that they do not bind at the bearings or are mechanically unsound.

(c) Controllers

Calibrate as follows:

- (i) move the set-point to the controller so that it is equivalent to the condition measured at the detector. It may be necessary to stabilise the conditions at the detector during this T&C Procedure;
- (ii) set the proportional band of the controller to the design value. For 2 and 3 term controllers, these settings should suit the characteristics of the plant;
- (iii) in the case of controllers, which are to be reset by other source signals, or other stage, signal inputs shall be connected in accordance with the calibration procedure for that particular instrument. For example, adjust 'Authority' settings as required and where applicable;
- (iv) with proportional controllers, incremental movements of the set-point should give proportional movement of the final control device in the required direction. Check that the total movement of the set-point to give full movement of the control device corresponding to the proportional band setting;
- (v) in the case of two-position control check that the switching action is correct and any internal heaters are disconnected during calibration;
- (vi) adjust the set-point to the specified desired value; make 'Dead Zone' adjustment where applicable;

- (vii) cancel any measures that may have been taken to stabilise the conditions at the detector thus returning the plant ready for normal working; and
- (viii) adjust proportional bands of controllers to attain the minimum deviation consistent with stable control. In the case of timed two-position and floating control systems, set the design differential and where applicable, the time interval which is consistent with stable control and the minimum deviation.

(d) DDC Controller

- (i) use an engineering tool e.g. portable computer;
- (ii) verify whether the control program is downloaded or not;
- (iii) verify the time and date of the real time clock;
- (iv) set correctly the data transmission rate of the controller; and
- (v) verify the proper communication in the network by checking the network indication;
- (vi) check the performance of the controller and calibrate the input and output points as follows:

1. Analogue input

- take the reading of the sensor connected to the controller;
- compare the reading with gauge reading or instrument reading; and
- calibrate the sensor if necessary. (calibration certificates should be submitted).

2. Digital input

- read the initial status of the point;

- manually start the equipment or simulate an alarm condition;
- verify the change of the status or appearance of alarm;
- resume the condition back to initial state; and
- verify the resumed condition.

3. Analogue output

- force the controller to give 0% output signal;
- verify the position of the actuator by sight or the running condition of the equipment by gauge reading;
- repeat the verification for 33%, 66% and 100% output signals; and
- calibrate the actuator if necessary. (calibration certificates should be submitted).

4. Digital output

- read the initial state of the point;
- force the controller to send ON or OPEN signal
- verify the proper action of the actuator or equipment by sight;
- force the controller to send OFF or CLOSE signal; and
- verify the resumed signal of the actuator or equipment by sight.

(e) Sequence Control

any interlocking or overriding devices should be checked to ensure that the overall sequence of control is achieved.

(f) Plant Operation

following the T&C procedures, the design conditions should be achieved and maintained for

a suitable period of observation with a minimum of one operation. If the conditions cannot be achieved or maintained, then a check on the final control devices should be carried out to ascertain that maximum correction has been applied. If this is not satisfied, investigation beyond the control system is needed.

4.3.3.1.4 Completion of T&C

The A/C Contractor shall submit the record document and drawings after the completion of T&C.

The final T&C report shall be kept in the Operating and Maintenance Manual for permanent reference and easy access.

4.3.3.2 Central Control Monitoring System (CCMS)

4.3.3.2.1 Off Site Preparatory Work

The A/C Contractor shall prepare and submit the document and drawing as specified in the General Specification to the PBSE for approval before carrying out the CCMS T&C work.

4.3.3.2.2 On the Site T&C Works

Pre-commissioning

Pre-commissioning shall include the checking of the installed software and hardware (e.g. wiring, sensors and actuators) and any items of plant with integral controllers;

The test equipment and instruments shall have been calibrated within the specified period according to the manufacturer's recommendations. The calibration certificates shall be submitted to PBSE for record;

All physical adjustments to the CCMS field devices shall be marked. Volt free and control terminals shall be checked such that they are separated from mains voltage.

(a) Checking and Set-up

(i) Level of CCMS Performance Checking

Checking the performance of a CCMS shall be conducted at several different levels:

- Level 1 : Component level

e.g. sensors, actuators, controllers / routers /gateways, terminal workstations, field devices;

- Level 2 : Sub-system performance
e.g. individual chillers, air handing units and equipment, etc.; and
- Level 3 : Building and zone performance
e.g. environmental control in zone or building.

The checking can be performed from the workstations (in a remote control room) or in the plant room itself. Level of CCMS performance testing is as shown in Figure 4.3.3.2.2 below.

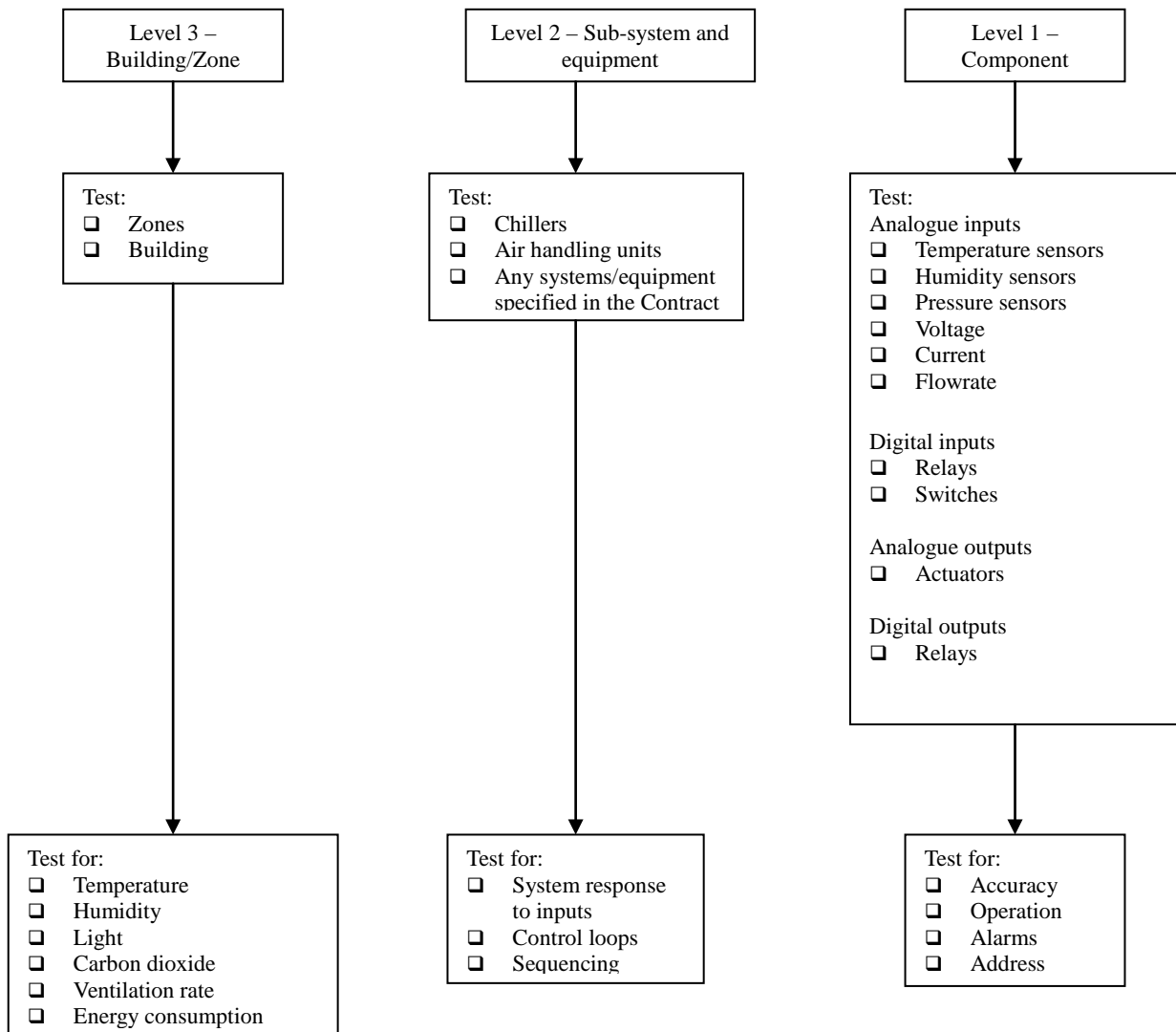

Fig. 4.3.3.2.2 – Levels of CCMS Performance Testing

(ii) Preliminary check

All major components are installed in accordance with the drawings.

(iii) Electrical Supply & Batteries

To check for correct power supply to the CCMS

(iv) Visual/Physical inspection

The A/C Contractor shall submit a checklist but not limited to the following for visual checking: -

1. CCMS wiring;
2. Field devices;
3. Controller /Router /Gateway /Interfacing Unit; and
4. CCMS Workstation/Server;

Visual inspection shall be carried out to check for any physical damage and assess the readiness for pre-commissioning. Defect list shall be raised to initiate the remedial work before commissioning;

5. Wiring

- correct type of cables according to the specification;
- identification of cables;
- security of fixing/protection of cables, etc.;
- secure termination of wires; and
- in accordance with the Electricity (Wiring) Regulations;

6. Sensors and actuators

- correct location/orientation;
- type as specified;
- actuator linkage connected and adjusted; and

- identification correct;
7. Digital inputs/outputs
- location as specified; and;
 - identification correct
8. Controller/Router/Gateway/Interfacing Unit
- type as specified;
 - mechanical fixing for Controller / Router / Gateway / Interfacing Unit firmly located;
 - identification correct;
 - all cables terminated and identified;
 - power available, i.e. correct and healthy electrical power supply;
 - hardware configuration in line with design;
 - all electronic devices in place; and
 - wiring diagram;
9. CCMS workstation/server
- type as specified;
 - sufficient power outlets available;
 - cleanliness for operation; and
 - data ports for network connection;
10. Control wiring connection
- cable type as specified;
 - cable identified at both ends;
 - correct input/output;
 - correct and secure termination;
 - separation of mains and signals cables; and

- no short circuits (line to line and line to earth).

(b) Component and System Checking

(i) Control Strategy/Software

The logic diagrams for CCMS can be used to check the software of CCMS

1. Set Points

- check that realistic numbers and ranges have been entered for all set points;

2. Time Control

- Check that suitable on/off times are entered for all timed routines, and that they operate the relevant plant as required;

3. Interlocks

- Check that all interlocks are in place and work-test by individually switching interlocked items of plant;

4. Control Loops

- Check that each control loop is in place and that the necessary default values have been added to enable testing to proceed;
- Test the operation of control loop.

5. Sequencing

- Check that sequence control is provided and it sequences plant in the specified manner;

6. Start-up & Shut down

- Check the start-up routine for the correct sequence of operations for the plant controls;
- Check that the defined restart routine is effective when power is reinstated after failure; and

- Run a similar check on the shut-down routine and check status of dampers, valves etc. after shut-down;

7. Plant Change Over

- The automatic change over of plant on plant failure or when a specified number of hours run has been reached should be checked by failing plant or “manually” increasing the hours run;

8. Alarm Function

- Check the operation of each alarm function; and
- Check the level or category of alarm, its destination and how it is reported;

9. Graphics

- Check the text display and graphics to avoid inconsistencies.

(ii) Controller/Router/Gateway/Interfacing Unit

1. Check that the “as built” drawings incorporate the latest modifications;
2. Check metalwork; hinges on doors, flush doors, opening and closing of doors, no sagging or drooping of doors when open, interlocking of doors;
3. Check secure operation of door locks;
4. Check for location and labelling of switches and indicators (including colour). Check that plastic rivets or screws are used to mount labels;
5. Check the scale of analogue/devices;
6. Check that: -
 - access for incoming/outgoing cables;
 - all doors/gland plates to be earthed;
 - tightness of all connections;

- colour coding and numbering of all cables as specified;
- numbering of all terminals;
- segregation of power cabling and switchgear from control cabling and electronic equipment.;
- connections between panel sections are numbered as specified, accessible and physically simple to connect / disconnect.;
- link type terminals for CCMS cables.;
- spare space is provided as specified.;
- labelling of equipment in Controller/Router/ Gateway/Interfacing Unit; and
- screen and earth connections cabling associated with CCMS equipment in compliance with manufacturer's installation requirements.

7. Sensors (See Annex IV Fig. 1)

- Check that the sensor output is within the expected range. The sensor output shall be compared with the reading on the test instrument;
- If a sensor is not linear over its working range, check the sensor at the upper, middle and lower points of its normal working range; and
- Check for offsets in the software.

8. Digital Signal (See Annex IV Fig. 2)

- Check that the signal is sensed correctly by the CCMS;
- Check that each contact is correctly at open or closed state and that it can change in response to the relevant item of plant being switched;

- If available, feedback signals from the digital outputs should be checked against the controlling digital outputs;
- Check the status lights on the digital output boards in the Controller/Router/Gateway/Interfacing Unit;
- If a device is switched on or off, the effect can usually be monitored by another CCMS input; and
- Check that no unexpected / additional / temporary software override or interlock have been enabled.

9. Analogue Signal (See Annex IV Fig. 3)

- Check the position indication signal that agrees with the analogue output signal to the actuator;
- Check the direction of movement and accuracy of position;
- Check that the relevant actuator is functioning correctly;
- With the valve or damper actuator in the closed position, check that there is no temperature changes across the heater/ cooler;
- Check that the actuator has the correct movement to give the required travel of the final control device;
- Ensure that any linkage adjustment for rotation, lift or close off have been suitably set;
- Check that in the case of spring return motor being fitted, the position assumed upon interruption of the power supply is correct; and
- Check that there is a smooth and regular movement of the actuating motor and regulator throughout this T&C Procedure.

10. Alarm Signal (See Annex IV Fig. 4)

- Adjust the alarm level to cause an alarm. Check that the address, alarm message and destination are correct; and
- Alarms can also apply to digital inputs, e.g. an overheat thermostat or a switch for a pump or fan;

11. Response to Sensor Failures

- Inspect the control strategy software; and
- Should there be a sensor failure where the output is used in a control loop, then the action of the loop should be checked;

12. Interlocks

- Check interlocks through written logic diagrams and read the text;
- Check when one particular activity happens, all related and interlocked activities also occur (positive checks); and
- Check that interlocked and related activities cannot occur in isolation (negative checks);

13. Control Loops (See Annex IV Fig. 5)

- Determine if loop is open (without feedback) or closed (with feedback); and
- Before checking the loops, verify the correct operation of the valve or dampers. Damper linkages may be disconnected, dampers jammed, valve jammed or passing etc.;

14. Open Loop Test (See Annex IV Fig. 5)

- Set up trend logs for the input and output of the loop;
- Switch the control loop to manual mode;

- Vary the signal to the actuator in a predefined test sequence covering the span from fully closed to fully open and log the output;
- Note that some control loops allow limits to be applied to an output signal, so an output range of 0-100% may not be achievable;
- Examine the profiles of the output and input; and
- Reset the controller to the required set point and to automatic mode;

15. Close Loop Test (See Annex IV Fig. 5)

- Trend-log the input and output to the control loop;
- Set the control to achieve the desired test conditions;
- Select the controls to achieve the desired test conditions;
- Select 2 set point values (they should be within 10% of each other) and set the controller to the first value;
- Check that the controller can maintain the set point;
- Monitor (trend-log) the transient behaviour and check if it is acceptable (i.e. the initial time taken for the response to settle to a steady level);
- Change the control to the second set point and check the transient behaviour and output level;
- If the set point cannot be achieved or maintained, or the system does not stabilise, the control loop should be returned and retested; and
- Reset the controller to the required set point and the automatic mode;

16. Field Device Location

- Check that the correct type of device is located in the correct position; and
- The identification or reference number of the device should be checked;

17. Field Device Wiring

- Visual check the wiring to the device, see if it is of the correct type, termination etc.; and
- At the Controller / Router / Gateway / Interfacing Unit and automatic control panel, check that the wiring is terminated and the manual/off/auto switches are set to automatic.

Commissioning

- (a) commissioning involves completing all the checks and the settings of control values to ensure the correct operational state of the Installations;
- (b) the CCMS Workstation shall be used to evaluate the performance of the completed system;
- (c) all variable parameters and switches shall be set to appropriate values and settings to ensure compliance with the Particular Specification;
- (d) check that the Controller/Router/Gateway/Interfacing Unit continues to function independently and in real time irrespective of any failure of the remainder of the CCMS;
- (e) CCMS workstation/server shall be used to check the communication networks, such as graphic functions, CCMS software, etc; and
- (f) a mains failure shall be simulated to check if the CCMS operation meets the Particular Specification when the electrical supply is interrupted;

Functional Test of System Performance

- (a) Functional Test of Workstation/Server
 - (i) Hardware Installation

1. Check ambient environment i.e. temperature and relative humidity;
2. Check the electrical power supply cable connected to UPS and eventually all workstation equipment power cables well terminated at UPS;
3. Check the cable connected to Controller / Router / Gateway / Interfacing Unit and ensure the wiring is correct; and
4. Check the LAN cable connected from Controller / Router / Gateway / Interfacing Unit to workstation.

(ii) Software Installation

1. Check correct type of software to be installed for the workstation;
2. Ensure the above software have been installed at workstation and check the set up of control system;
3. Test and execute the control task;
4. Demonstrate that all relevant information can be monitored and controlled through the Workstation; and
5. The software license of operation and ownership shall be included in the Operating and Maintenance Manuals.

(b) Functional Test of Controller / Router / Gateway / Interfacing Unit

(i) Installation

1. Check the Controller / Router / Gateway / Interfacing Unit and accessories are properly set;
2. Check the sensors, transducers, valves, actuators, AHU, PAU, FCU, VAV, ventilation fans, frequency inverters are properly installed according to drawings, etc.;
3. Check the Installations and services interfacing with CCMS; and

4. Check the gateway/interfacing Unit for relevant systems and equipment;

(ii) Testing Procedures for Controller

1. Put controller into operation (on-line);
2. Check the controller is functioning;
3. Check the data communication among workstation when controller start operating;
4. Check the input and output of controller as well as the field points and ensure the system can transmit a correct signal;
5. Check whether the field points can be assigned through workstation;
6. Test I/O points with controllers and Building Services Installations which monitor and control through CCMS to ensure whole system is installed correctly;
7. Put the system into an auto mode and test if the program can run properly; and
8. Use the workstation or Portable Operator Terminal to carry out the modification;

(c) Interface between CCMS and Other Connected Equipment/ Systems

The A/C Contractor shall carry out the T&C with other contractors to ensure the success of signal input/output between the CCMS and any other connected equipment/systems; and

(d) Commissioning Data and Storage

A copy of all commissioning data of each system/equipment shall be submitted to the PBSE for approval. The commissioning data shall be included in Operating and Maintenance Manuals at handover. The commissioning data shall include sensor accuracy, alarm delays, actuator movement, control loop settings plus input and outputs.

4.3.3.2.3 Completion of T&C

The A/C Contractor shall submit the following record documents and drawings after the completion of commissioning and testing:

(a) Backup copy of CCMS software

the back-up copies of the latest version of all the software shall be made. After changes have been made in the software following the performance tests, a new back-up copy of the software shall be made, while still retaining a copy of the previous version shall problems arise;

(b) O&M manual

since the control strategies, set points, alarm levels etc. are software based, an up-to-date hard copy needs to be kept in the Operating and Maintenance Manual for permanent reference and easy access.

4.3.4 Noise and Sound Tests

4.3.4.1 Checking Procedures

Before noise level tests are undertaken, the following preliminary checks shall be carried out:-

- (a) All air-conditioning and mechanical ventilation (ACMV) systems are dynamically tested and balanced in accordance with the relevant Sections of this document;
- (b) All building works are completed and areas under test are vacated or under control for carrying out the noise test;
- (c) All other noise generating activities and equipment are stopped.

Where circumstances require certain equipment to be kept operational, then this shall be clearly indicated on the final test data sheets; and

- (d) All areas under test are provided with safe access.

4.3.4.2 Noise Screening Test

The A/C Contractor shall carry out screening test on all noise emitting plant and machineries during the pre-commissioning phase of the installation work to identify potential problems that might infringe the Noise Control Ordinance.

The A/C Contractor shall submit to the Supervising Officer the test results and to notify the Supervising Officer on any likely problematic areas so that prompt action could be followed up.

4.3.4.3 General Requirements

Site ambient noise levels shall be recorded prior to the commencement of tests. In order to minimise the effect of background noise, noise levels at external areas shall be measured at night or at other representative time as agreed with the Supervising Officer.

Prior to measurement of noise levels, the A/C Contractor shall check that all the plants in the air system and the water system are running.

If any item of plant is not running during the test, it shall be clearly identified on the test sheets.

Noise levels shall be measured by an approved noise level meter (or sound meter) capable of measuring noise levels in the frequency range of 63 Hz to 8 kHz.

Noise level tests of the selected A/C system shall include sound pressure readings relating to the NC levels in each room where stated in the Contract Drawings or in the Particular Specification.

In each selected area, noise levels shall be measured at 1.5 metres above the finished floor level and at a distance of 1.5 metres from the walls or doors of the areas.

In large areas, the floor area shall be divided into equal areas and readings carried out in each area.

The A/C Contractor shall carry out external noise level tests in locations at agreed boundary positions.

In order to minimise the effect of background noise, noise levels at external areas shall be measured at night or at other representative time as agreed with the Supervising Officer.

Upon completion of the noise level tests, the A/C Contractor shall carry out a further set of noise level measurement with all plant off, so as to verify again the level of background noise.

In cases where measured noise levels are in excess of the specified criteria, additional checks shall be carried out to identify the sources of excessive noise generation.

All noise level readings are to be recorded and plotted on octave wave band frequency charts.

The date and time of test are also to be recorded together with any relative comments.

4.3.4.4 Indoor Noise Level Measurement

All the effort in designing the indoor ACMV system with care and thought might be wasted if installation and commissioning of the equipment is not proper. The following check points shall be followed to determine if the total noise level in occupied areas within the building exceed the limits as specified in the Specification.

- (a) calibrate the sound level meter with sound level calibrator supplied with the meter according to the procedures specified in the operation manual of the meter;
- (b) switch on the ACMV equipment or plant serving the area in which noise is to be assessed. The corresponding fan coil units, ventilation fans and other sound source(s) affecting the area shall also be turned on;
- (c) measure Sound Pressure Levels (SPLs) in dB. Measurement shall be made as close to the diffuser as possible and the position of the sound level meter shall be at a height of 1.5m above floor level is considered appropriate for general situations;
- (d) indicate clearly the locations of measurement on a floor layout plan for the area(s) concerned;
- (e) record the SPLs measured from the 63 Hz octave band through the 8000 Hz octave frequency band in Certificate no. 21.1 of Annex II;
- (f) plot the SPLs on typical Noise Criteria (NC) curves to determine the measured NC level in each area;
- (g) also indicate other relevant information including date and time of measurement; type, model and calibration date of the meter used as well as other observations during the measurement process in Certificate no. 21.1 of Annex II;
- (h) re-calibrate the meter with the calibrator after the noise measurement; and
- (i) measure background noise level only if the ambient noise level in the area, with the ACMV equipment not operating, exceeds the NC limits as specified in the Specification.

4.3.4.5 Outdoor Noise Level Measurement

The noise level measurement is performed to assess the noise generated from ACMV equipment like chillers, ventilation fans, etc., which may cause nuisance to noise sensitive receivers outside the building in which the equipment is placed.

The procedures below are generally in compliance with those set in the requirements in the Noise Control Ordinance:

- (a) calibrate the meter with sound level calibrator supplied with the meter according to the procedures specified in the operation manual of the meter;
- (b) measure noise levels at the location/point to be assessed. The location/point to be assessed could be the potential 'noise sensitive receiver' according to the 'Technical Memorandum for the Assessment of Noise from Places other than Domestic Premises, Public Places or Construction Sites' (TM) issued by the Environmental Protection Department (EPD);
- (c) indicate clearly the locations of the noise emitting source and measuring point(s) on a site plan.
- (d) where a measurement is to be carried out at a building, the assessment point shall be at a position 1m from the exterior of the building façade but may be at any other point considered to be appropriate by the EPD. Where a measurement is to be made of noise being received at a place other than a building, the assessment point shall be at a position 1.5m above the ground, at a particular point considered appropriate by the EPD;
- (e) measure the Equivalent Continuous Sound Level (Leq) in dBA over a period of 30 minutes according to the TM. Measurement can be made over any shorter period when the EPD is satisfied that the noise under investigation is essentially steady over a 30-minute period;
- (f) record the figures of Leq measured together with the corresponding time period at which the measurement is conducted in Certificate no. 21.2 of Annex II;
- (g) correction for Tonality, Impulsiveness and/or Intermittency shall be required according to the conditions set out in the TM;
- (h) also indicate other relevant information including date of measurement; type, model and calibration date of the meter used; weather condition as well as other observations during the measurement process in Certificate no. 21.2 of Annex II; and
- (i) re-calibrate the meter with the calibrator after the noise measurement.

4.3.5 Vibration Tests

Testing for equipment vibration is necessary as an acceptance test to determine whether equipment is functioning properly and to ensure that objectionable vibration and noise are not transmitted. As the vibration acceptance test is based on root mean square (r.m.s.) velocity (mm/s) only, frequency measurement is not required. Vibration measurement shall be taken after the equipment had been running for 2 weeks.

- (a) record the operating speeds of the equipment (i.e. driving speed of motor and driven speed of fan wheel, rotor or impeller) indicated on the nameplates, drawings or measured by speed-measuring device in Certificate no. 22 of Annex II;
- (b) determine acceptance criteria from the Particular Specification or as indicated below;

Equipment	Allowable rms velocity, mm/s
Pumps	3.3
Centrifugal Compressors	3.3
Fans	2.3

- (c) perform visual and audible checks for any apparent rough operation of the equipment or any defective bearings, misalignment, etc;
- (d) calibrate the vibration measuring instrument according to the user's manual;
- (e) measure and record in Certificate no. 22 of Annex II vibration at bearings of driving and driven components in horizontal, vertical and, if possible, axial directions. There should be at least one axial measurement for each rotating component (fan motor, pump motor);
- (f) indicate other relevant information including date of measurement, type, model and calibration date of the instrument used as well as other observations in the measurement process in Certificate no. 22 of Annex II; and
- (g) re-calibrate the instrument after the measurement.

4.3.6 Electrical Tests

4.3.6.1 Electrical Tests on Motor Control Switchboard

- (a) The tests shall be carried out before and after connection of power supply. The tests shall follow the requirements for L.V. Cubicle Switchboard as stipulated in the General Specification for Electrical Installation in Government Buildings of the HKSAR issued by ArchSD; and

- (b) The tests to be carried out for the high voltage motor control switchboard shall strictly follow the tests as recommended by the equipment manufacturer.

4.3.6.2 Electrical Tests on Motor

(a) Required Tests

The A/C Contractor shall carry out the following tests on all electrical motors and provide test certificates in duplicate:-

- (i) Check motor nameplate characteristic such as voltage and frequency & etc.;
- (ii) Check motor rotation and speed, prior to connection of the driven equipment;
- (iii) Ascertain maximum kW absorbed by fan at the most demanding point of the pressure/volume characteristic curve at the specified fan speed;
- (iv) Check the earth continuity loop resistance for every motor starter;
- (v) Check the insulation to earth resistance for every motor starter taken with 500 V "Meggar" tester;
- (vi) Test the full load current taken by all motors on each phase;
- (vii) Test the tripping time of starter overloads set to 10% above the motor nameplate rating;
- (viii) Test the function of each control unit in accordance with the specification (e.g. selector switches correctly wired, high or low circuit cut-out operates, level switches correctly operating);
- (ix) Check motor temperature; and
- (x) Check starting current of each motor.

(b) Type Tests

Type tests and abbreviated tests shall meet the requirements of IEC 60072-1 [1991], IEC 60072-2 [1990] and IEC 60072-3 [1994]. The Supervising Officer has the discretion to agree or accept type-test results for performance in place of individual unit tests but these will not be accepted in place of practical on the Site, pressure, insulation, resistance tests which shall still be carried out on individual units.

(c) A/C Contractor's Responsibility

Approval of test certificates shall not absolve the A/C Contractor from providing motors capable of driving the various items of plant under the conditions of loading stated in the tender documents.

4.3.7 Final Air Conditioning System Performance Tests

4.3.7.1 General

On completion of all inspections and tests, a final overall performance test shall be carried out on the air-conditioning installation.

4.3.7.2 Instruments

The A/C Contractor shall provide the following calibrated instruments for this test:-

- (a) All necessary wet and dry bulb mercury-in-glass thermometers;
- (b) A wet and dry bulb weekly recorder;
- (c) Where specified, multi-point recorders with service devices for monitoring temperature, humidity, current, voltage, etc.;
- (d) Surface contact dial indicating pyrometer;
- (e) A sound meter capable of reading the noise level at 62.5, 125, 250, 500, 1000, 2000, 4000 and 8000 Hertz; and
- (f) Other equipment as found necessary or instructed.

4.3.7.3 Method of Testing

During this test, the air conditioning systems shall be operated for a period of 5 days minimum. During which time, the following shall be noted and the results compared with the design criteria:-

- (a) Note occupation rates, internal heat and humidity loads, and external conditions at time of test;
- (b) Obtain temperature and humidity levels throughout all spaces;
- (c) Obtain sound levels for all critical areas;
- (d) Record exhaust and outdoor air extract system ventilation rates;

- (e) Check efficiency of individual direct expansion refrigeration/cooling systems in accordance with CIBSE Commissioning Code 'R' - Refrigerating Systems;
- (f) Check capability of chilled water system to maintain chilled water flow and return temperature under full load conditions; and
- (g) Check electrical loadings of all plants when operating under both full load and part load conditions.

4.3.7.4 Full Load Requirement

When full load conditions cannot be achieved during the commissioning tests, the A/C Contractor shall allow for returning to site to carry out a full load test when the desirable external and internal design conditions occur at the first opportunity during the Maintenance Period.

For particularly sensitive areas such as computer rooms, simulated full load tests shall be carried out at the time of commissioning using electric heaters to simulate the sensible load and electric steam pan humidifiers to simulate the latent load.

4.3.7.5 When calculating the required simulated load, the following shall be taken into account.

- (a) the anticipated heat gain from plant and machinery;
- (b) the extra heat gain through the structural fabric due to the difference between the design external air temperature and the external air temperature at the time of the tests;
- (c) the extra solar heat gain at maximum design conditions over that experienced at the time of the tests;
- (d) the extra heat gain from the fresh air quantity due to the difference between the design external air temperature and the external air temperature at the time of the tests;
- (e) the extra sensible and latent (if significant) heat gains due to the increase in the number of occupants normally present (i.e. allowed for in the design) over the number present at the time of the tests; and
- (f) NOTE: The areas where simulated load tests are to be carried out shall be clearly indicated in the Particular Specification.

Testing and Commissioning Progress Chart for Air-conditioning, Refrigeration, Ventilation and Central Monitoring & Control System Installation

Contract No. : _____

Contract Title: _____

Name of A/C Contractor/Sub-contractor: _____

Contract Period: / /20 to / /20 *Revised/Actual Completion Date: / /20
dd/mm/yyyy dd/mm/yyyy dd/mm/yyyy

T&C Progress Chart for Air-conditioning, Refrigeration, Ventilation and Central Monitoring & Control Systems (Rev.) (Note 1)																			
		Dates (Note 2)																	Remark
Activities	Reference to T&C Procedure		S	A	S	A	S	A	S	A	S	A	S	A	S	A	S	A	
1.	Chillers																		
1.1	Cleanliness & State Check	Clause 4.2.3.1.1																	
1.1.1	Air System	Clause 4.2.3.1.2(b)																	
1.1.2	Water System	Clause 4.2.3.1.2(a)																	
1.1.3	Refrigeration System	Clause 4.2.3.1.2(c)																	
	Submission of Record of Test																		
1.2	Mechanical Check	Clause 4.2.3.1.3																	
1.2.1	Fans	Clause 4.2.3.1.3(a)																	
1.2.2	Pumps																		
1.2.3	Compressors	Clause 4.2.3.1.3(b)																	
1.2.4	Drives	Clause (iii)c of 4.2.3.1.3(c)																	
	Submission of Record of Test																		

Testing and Commissioning Progress Chart for Air-conditioning, Refrigeration, Ventilation and Central Monitoring & Control System Installation

T&C Progress Chart for Air-conditioning, Refrigeration, Ventilation and Central Monitoring & Control Systems (Rev.) (Note 1)																			
	Activities	Reference to T&C Procedure	Dates (Note 2)																Remark
			S	A	S	A	S	A	S	A	S	A	S	A	S	A	S	A	
1.3	Electrical Check	Clause 4.2.3.1.4																	
1.3.1	Electrical Supplies Isolated	Clause 4.2.3.1.4(a)																	
1.3.2	Electrical Supplies Connected	Clause 4.2.3.1.4(b)																	
	Submission of Record of Test																		
1.4	Test of Reciprocating Compressor System	Clause 4.2.3.2																	
1.4.1	Pressure & Leakage Test	Clause 4.2.3.2.1																	
1.4.2	Evacuation & Dehydration	Clause 4.2.3.2.2																	
1.4.3	Charging of Refrigerant	Clause 4.2.3.2.4																	
1.4.4	Setting to Work & Adjusting	Clause 4.2.3.2.5																	
	Submission of Record of Test																		
1.5	Test of Centrifugal Compressor System (Including Oil Free Compressor)	Clause 4.2.3.3																	
1.5.1	Pressure & Leakage Test	Clause 4.2.3.3.1																	
1.5.2	Evacuation & Dehydration	Clause 4.2.3.3.2																	
1.5.3	Charging of Refrigerant	Clause 4.2.3.3.4																	
1.5.4	Setting to Work & Adjusting	Clause 4.2.3.3.5																	
	Submission of Record of Test																		

Testing and Commissioning Progress Chart for Air-conditioning, Refrigeration, Ventilation and Central Monitoring & Control System Installation

T&C Progress Chart for Air-conditioning, Refrigeration, Ventilation and Central Monitoring & Control Systems (Rev.) (Note 1)																					
	Activities	Reference to T&C Procedure	Dates (Note 2)																		Remark
			S	A	S	A	S	A	S	A	S	A	S	A	S	A	S	A	S	A	
1.6	Test of Screw Compressor System	Clause 4.2.3.5																			
1.6.1	Pressure & Leakage Test	Clause 4.2.3.5.1																			
1.6.2	Evacuation & Dehydration	Clause 4.2.3.5.2																			
1.6.3	Charging of Refrigerant	Clause 4.2.3.5.4																			
1.6.4	Setting to Work & Adjusting	Clause 4.2.3.5.5																			
	Submission of Record of Test																				
1.7	Testing of Absorption Chillers	Clause 4.2.3.4																			
1.7.1	General Check of System Components	Clause 4.2.3.4																			
1.7.2	Leak Test of Absorption Shell and Purge Unit	Clause 4.2.3.4.1																			
1.7.3	Evacuation of Absorption System	Clause 4.2.3.4.2																			
1.7.4	Charging of Refrigerant	Clause 4.2.3.4.4																			
1.7.5	Setting to Work & Adjusting	Clause 4.2.3.4.5																			
	Submission of Record of Test																				
1.8	Functional Test for Air & Water Cooled Chillers	Clause 4.2.3 & Annex II																		Setting to work & record	

Testing and Commissioning Progress Chart for Air-conditioning, Refrigeration, Ventilation and Central Monitoring & Control System Installation

T&C Progress Chart for Air-conditioning, Refrigeration, Ventilation and Central Monitoring & Control Systems (Rev.) (Note 1)																		Remark		
		Dates (Note 2)																		
Activities	Reference to T&C Procedure	S	A	S	A	S	A	S	A	S	A	S	A	S	A	S	A	S	A	
1.8.1	Chilled Water Leaving Temperature																			
1.8.2	Chilled Water Entering Temperature																			
1.8.3	Chilled Water Flow Rate																			
1.8.4	Condenser Entering Temperature (Water Cooled Chillers)																			
1.8.5	Condenser Leaving Temperature (Water Cooled Chillers)																			
1.8.6	Compressor Motor Speed																			
1.8.7	Compressor Running Current																			
1.8.8	Air Flow Rate (Air Cooled Chillers)																			
1.8.9	Fan Speed (Air Cooled Chillers)																			
1.8.10	Fan Motor Speed (Air Cooled Chillers)																			
1.8.11	Fan Motor Running Current																			
1.8.12	Supply Voltage																			
	Submission of Record of Test																			
1.9	Functional Test for Air Absorption Chillers	Clause 4.2.3 & Annex II																		Setting to work & record
	Submission of Record of Test																			

Testing and Commissioning Progress Chart for Air-conditioning, Refrigeration, Ventilation and Central Monitoring & Control System Installation

T&C Progress Chart for Air-conditioning, Refrigeration, Ventilation and Central Monitoring & Control Systems (Rev.) (Note 1)		Dates (Note 2)																			Remark	
Activities	Reference to T&C Procedure	S	A	S	A	S	A	S	A	S	A	S	A	S	A	S	A	S	A	S	A	
2.	Chilled Water System																					
2.1	Cleanliness & State Check	Clause 4.1.6.1																				
	G/F																					
	1/F																					
	2/F																					
	3/F																					
	4/F																					
	Submission of Record of Test																					
2.2	Mechanical Check	Clause 4.1.6.4																				
	G/F																					
	1/F																					
	2/F																					
	3/F																					
	4/F																					
	Submission of Record of Test																					
2.3	General Checking	Clause 4.1.6.3																				
	G/F																					
	1/F																					
	2/F																					
	3/F																					
	4/F																					
	Submission of Record of Test																					

Testing and Commissioning Progress Chart for Air-conditioning, Refrigeration, Ventilation and Central Monitoring & Control System Installation

T&C Progress Chart for Air-conditioning, Refrigeration, Ventilation and Central Monitoring & Control Systems (Rev.) (Note 1)		Dates (Note 2)																		Remark
	Activities	Reference to T&C Procedure	S	A	S	A	S	A	S	A	S	A	S	A	S	A	S	A	S	A
2.4	Electrical Check (Pumps)	Clause 4.1.5																		
2.4.1	Electrical Supply Isolated	Clause 4.1.5.1																		
	Pri.																			
	Sec.																			
	Submission of Record of Test																			
2.4.2	Electrical Supply Available	Clause 4.1.5.2																		
	Pri.																			
	Sec.																			
	Submission of Record of Test																			
2.5	Initial Running of Pump Sets	Clause 4.2.1.4																		
2.5.1	Pump Discharge Rate	Clause 4.2.1.4																		
	Pri.																			
	Sec.																			
	Submission of Record of Test																			
2.5.2	Pump Suction Pressure	Clause 4.2.1.4																		
	Pri.																			
	Sec.																			
	Submission of Record of Test																			

Testing and Commissioning Progress Chart for Air-conditioning, Refrigeration, Ventilation and Central Monitoring & Control System Installation

T&C Progress Chart for Air-conditioning, Refrigeration, Ventilation and Central Monitoring & Control Systems (Rev.) (Note 1)																					
		Dates (Note 2)																			Remark
Activities	Reference to T&C Procedure		S	A	S	A	S	A	S	A	S	A	S	A	S	A	S	A	S	A	
2.5.3	Pump discharge Pressure	Clause 4.2.1.4																			
	Pri.																				
	Sec.																				
	Submission of Record of Test																				
2.5.4	Pump Motor Speed	Clause 4.2.1.4																			
	Pri.																				
	Sec.																				
	Submission of Record of Test																				
2.5.5	Pump Motor Current	Clause 4.2.1.4																			
	Pri.																				
	Sec.																				
	Submission of Record of Test																				
2.5.6	Supply Voltage	Clause 4.2.1.4																			
	Pri.																				
	Sec.																				
	Submission of Record of Test																				

Testing and Commissioning Progress Chart for Air-conditioning, Refrigeration, Ventilation and Central Monitoring & Control System Installation

T&C Progress Chart for Air-conditioning, Refrigeration, Ventilation and Central Monitoring & Control Systems (Rev.) (Note 1)																				
		Dates (Note 2)																		Remark
Activities	Reference to T&C Procedure		S	A	S	A	S	A	S	A	S	A	S	A	S	A	S	A	S	A
2.5.7	Non-return Valve Operation	Clause 4.2.1																		
	Pri.																			
	Sec.																			
	Submission of Record of Test																			
2.5.8	Isolation Valve Operation	Clause 4.2.1																		
	Pri.																			
	Sec.																			
	Submission of Record of Test																			
2.5.9	Flexible Joint	Clause 4.2.1																		
	Pri.																			
	Sec.																			
	Submission of Record of Test																			
2.6	Chemical Treatment	Clause 4.2																		
2.6.1	Cleanliness & State Check																			
2.6.2	Mechanical Check																			
2.6.3	Electrical Check																			
2.6.4	General Check																			
2.6.5	Initial Running of Chemical Dosing Pump																			
	Submission of Record of Test																			

Testing and Commissioning Progress Chart for Air-conditioning, Refrigeration, Ventilation and Central Monitoring & Control System Installation

T&C Progress Chart for Air-conditioning, Refrigeration, Ventilation and Central Monitoring & Control Systems (Rev.) (Note 1)																		Remark					
		Dates (Note 2)																					
Activities	Reference to T&C Procedure	S	A	S	A	S	A	S	A	S	A	S	A	S	A	S	A	S	A	S	A		
3.	Air Distribution System																						
3.1	Cleanliness & State Check	Clause 4.1.7.1																					
	G/F																						
	1/F																						
	2/F																						
	3/F																						
	4/F																						
	Submission of Record of Test																						
3.2	Fire & Smoke System Check																						
3.2.1	Regulating Device	Clause 4.1.7.2																					
	G/F																						
	1/F																						
	2/F																						
	3/F																						
	4/F																						
	Submission of Record of Test																						
3.2.2	Visual Check on Air Tightness	Clause 4.1.7.3																					
	G/F																						
	1/F																						
	2/F																						
	3/F																						
	4/F																						
	Submission of Record of Test																						

Testing and Commissioning Progress Chart for Air-conditioning, Refrigeration, Ventilation and Central Monitoring & Control System Installation

T&C Progress Chart for Air-conditioning, Refrigeration, Ventilation and Central Monitoring & Control Systems (Rev.) (Note 1)																		Remark			
		Dates (Note 2)																			
Activities	Reference to T&C Procedure		S	A	S	A	S	A	S	A	S	A	S	A	S	A	S	A	S	A	
3.2.3	Leakage Test																				
	G/F																				
	1/F																				
	2/F																				
	3/F																				
	4/F																				
	Submission of Record of Test																				
3.2.4	Mechanical Check on Fans & Dampers	Clause 4.1.7.4																			
	G/F																				
	1/F																				
	2/F																				
	3/F																				
	4/F																				
	Submission of Record of Test																				
3.2.5	Initial Running of Fans & Dampers																				
	G/F																				
	1/F																				
	2/F																				
	3/F																				
	4/F																				
	Submission of Record of Test																				

Testing and Commissioning Progress Chart for Air-conditioning, Refrigeration, Ventilation and Central Monitoring & Control System Installation

T&C Progress Chart for Air-conditioning, Refrigeration, Ventilation and Central Monitoring & Control Systems (Rev.) (Note 1)																		Remark				
		Dates (Note 2)																				
Activities	Reference to T&C Procedure		S	A	S	A	S	A	S	A	S	A	S	A	S	A	S	A	S	A		
3.2.6	Regulating of Air Flow																					
	G/F																					
	1/F																					
	2/F																					
	3/F																					
	4/F																					
	Submission of Record of Test																					
3.2.7	Functional & Performance Test	Clause 4.3.2																				
	G/F																					
	1/F																					
	2/F																					
	3/F																					
	4/F																					
	Submission of Record of Test																					
3.3	Fire Tripping & Safety Cutout																					
3.3.1	Electrical Check	Clause 4.1.5																				
	G/F																					
	1/F																					
	2/F																					
	3/F																					
	4/F																					
	Submission of Record of Test																					

Testing and Commissioning Progress Chart for Air-conditioning, Refrigeration, Ventilation and Central Monitoring & Control System Installation

T&C Progress Chart for Air-conditioning, Refrigeration, Ventilation and Central Monitoring & Control Systems (Rev.) ⁽¹⁾																		Remark					
		Dates (Note 2)																					
Activities	Reference to T&C Procedure	S	A	S	A	S	A	S	A	S	A	S	A	S	A	S	A	S	A	S	A		
3.3.2	Functional & Performance Test	Clause 4.3.2																					
	G/F																						
	1/F																						
	2/F																						
	3/F																						
	4/F																						
	Submission of Record of Test																						
3.4	Fire & Smoke Dampers Check																						
3.4.1	Cleanliness & State Check	Clause 4.1.7.1																					
	G/F																						
	1/F																						
	2/F																						
	3/F																						
	4/F																						
	Submission of Record of Test																						
3.4.2	Functional & Performance Test	Clause 4.3.2																					
	G/F																						
	1/F																						
	2/F																						
	3/F																						
	4/F																						
	Submission of Record of Test																						

Testing and Commissioning Progress Chart for Air-conditioning, Refrigeration, Ventilation and Central Monitoring & Control System Installation

T&C Progress Chart for Air-conditioning, Refrigeration, Ventilation and Central Monitoring & Control Systems (Rev.) (Note 1)																		Remark				
		Dates (Note 2)																				
Activities	Reference to T&C Procedure	S	A	S	A	S	A	S	A	S	A	S	A	S	A	S	A	S	A	S	A	
3.4.3	Electrical Check	Clause 4.1.5																				
	G/F																					
	1/F																					
	2/F																					
	3/F																					
	4/F																					
	Submission of Record of Test																					
3.5	Mechanical Ventilation System Check																					
3.5.1	Cleanliness & State Check	Clause 4.1.7.1																				
	G/F																					
	1/F																					
	2/F																					
	3/F																					
	4/F																					
	Submission of Record of Test																					
3.5.2	Regulating Device	Clause 4.1.7.2																				
	G/F																					
	1/F																					
	2/F																					
	3/F																					
	4/F																					
	Submission of Record of Test																					

Testing and Commissioning Progress Chart for Air-conditioning, Refrigeration, Ventilation and Central Monitoring & Control System Installation

T&C Progress Chart for Air-conditioning, Refrigeration, Ventilation and Central Monitoring & Control Systems (Rev.) (Note 1)		Dates (Note 2)																			Remark
	Activities	Reference to T&C Procedure	S	A	S	A	S	A	S	A	S	A	S	A	S	A	S	A	S	A	
3.5.3	Visual Check on Air Tightness	Clause 4.1.7.3																			
	G/F																				
	1/F																				
	2/F																				
	3/F																				
	4/F																				
	Submission of Record of Test																				
3.5.4	Leakage Test																				
	G/F																				
	1/F																				
	2/F																				
	3/F																				
	4/F																				
	Submission of Record of Test																				
3.5.5	Electrical Check	Clause 4.1.5																			
	G/F																				
	1/F																				
	2/F																				
	3/F																				
	4/F																				
	Submission of Record of Test																				
3.5.6	Mechanical Check of Fans, etc.	Clause 4.1.7.4																			
	G/F																				
	1/F																				
	2/F																				
	3/F																				
	4/F																				
	Submission of Record of Test																				

Testing and Commissioning Progress Chart for Air-conditioning, Refrigeration, Ventilation and Central Monitoring & Control System Installation

T&C Progress Chart for Air-conditioning, Refrigeration, Ventilation and Central Monitoring & Control Systems (Rev.) (Note 1)		Dates (Note 2)																			Remark		
Activities	Reference to T&C Procedure	S	A	S	A	S	A	S	A	S	A	S	A	S	A	S	A	S	A	S	A		
3.5.7	Initial Running of Fans	Clause 4.2.2.4																					
	G/F																						
	1/F																						
	2/F																						
	3/F																						
	4/F																						
	Submission of Record of Test																						
3.5.8	Regulating of Flow	Clause 4.2.2.5																					
	G/F																						
	1/F																						
	2/F																						
	3/F																						
	4/F																						
	Submission of Record of Test																						
3.5.9	Function & Performance Test	Clause 4.3.2																					
	G/F																						
	1/F																						
	2/F																						
	3/F																						
	4/F																						
	Submission of Record of Test																						

Testing and Commissioning Progress Chart for Air-conditioning, Refrigeration, Ventilation and Central Monitoring & Control System Installation

T&C Progress Chart for Air-conditioning, Refrigeration, Ventilation and Central Monitoring & Control Systems (Rev.) (Note 1)																		Remark				
		Dates (Note 2)																				
Activities	Reference to T&C Procedure		S	A	S	A	S	A	S	A	S	A	S	A	S	A	S	A	S	A		
3.6	Check of Conditioned Air Distribution																					
3.6.1	Cleanliness & State Check	Clause 4.1.7.1																				
	G/F																					
	1/F																					
	2/F																					
	3/F																					
	4/F																					
	Submission of Record of Test																					
3.6.2	Regulating Device	Clause 4.1.7.2																				
	G/F																					
	1/F																					
	2/F																					
	3/F																					
	4/F																					
	Submission of Record of Test																					
3.6.3	Visual Check on Air Tightness	Clause 4.1.7.3																				
	G/F																					
	1/F																					
	2/F																					
	3/F																					
	4/F																					
	Submission of Record of Test																					

Testing and Commissioning Progress Chart for Air-conditioning, Refrigeration, Ventilation and Central Monitoring & Control System Installation

T&C Progress Chart for Air-conditioning, Refrigeration, Ventilation and Central Monitoring & Control Systems (Rev.) (Note 1)																		Remark			
		Dates (Note 2)																			
	Activities	Reference to T&C Procedure	S	A	S	A	S	A	S	A	S	A	S	A	S	A	S	A	S	A	
3.6.4	Leakage Test																				
	G/F																				
	1/F																				
	2/F																				
	3/F																				
	4/F																				
	Submission of Record of Test																				
3.6.5	Electrical Check	Clause 4.1.5																			
	G/F																				
	1/F																				
	2/F																				
	3/F																				
	4/F																				
	Submission of Record of Test																				
3.6.6	Insulation Check																				
	G/F																				
	1/F																				
	2/F																				
	3/F																				
	4/F																				
	Submission of Record of Test																				
3.6.7	Mechanical Check	Clause 4.1.7.4																			
	G/F																				
	1/F																				
	2/F																				
	3/F																				
	4/F																				
	Submission of Record of Test																				

Testing and Commissioning Progress Chart for Air-conditioning, Refrigeration, Ventilation and Central Monitoring & Control System Installation

T&C Progress Chart for Air-conditioning, Refrigeration, Ventilation and Central Monitoring & Control Systems (Rev.) (Note 1)		Dates (Note 2)																			Remark		
Activities	Reference to T&C Procedure	S	A	S	A	S	A	S	A	S	A	S	A	S	A	S	A	S	A	S	A		
3.6.8	Initial Running of Fans & All Moving Parts	Clause 4.2.2.4																					
	G/F																						
	1/F																						
	2/F																						
	3/F																						
	4/F																						
	Submission of Record of Test																						
3.6.9	Regulating Air Flow	Clause 4.2.2.5																					
	G/F																						
	1/F																						
	2/F																						
	3/F																						
	4/F																						
	Submission of Record of Test																						
3.6.10	Flow Balancing																						
	G/F																						
	1/F																						
	2/F																						
	3/F																						
	4/F																						
	Submission of Record of Test																						

Testing and Commissioning Progress Chart for Air-conditioning, Refrigeration, Ventilation and Central Monitoring & Control System Installation

T&C Progress Chart for Air-conditioning, Refrigeration, Ventilation and Central Monitoring & Control Systems (Rev.) (Note 1)																		Remark					
		Dates (Note 2)																					
Activities	Reference to T&C Procedure	S	A	S	A	S	A	S	A	S	A	S	A	S	A	S	A	S	A	S	A		
3.6.11	Functional & Performance Test	Clause 4.3.2																					
	G/F																						
	1/F																						
	2/F																						
	3/F																						
	4/F																						
	Submission of Record of Test																						
3.7	Check of Control System	Clause 4.3.1.1.1																					
3.7.1	Visual Inspection																						
	G/F																						
	1/F																						
	2/F																						
	3/F																						
	4/F																						
	Submission of Record of Test																						
3.7.2	Basic Function Test	Clause 4.3.1.1.2																					
	G/F																						
	1/F																						
	2/F																						
	3/F																						
	4/F																						
	Submission of Record of Test																						

Testing and Commissioning Progress Chart for Air-conditioning, Refrigeration, Ventilation and Central Monitoring & Control System Installation

T&C Progress Chart for Air-conditioning, Refrigeration, Ventilation and Central Monitoring & Control Systems (Rev.) (Note 1)																					
	Activities	Reference to T&C Procedure	Dates (Note 2)																		Remark
			S	A	S	A	S	A	S	A	S	A	S	A	S	A	S	A			
3.7.3	Electrical Check	Clauses 4.3.1.1.3 4.3.1.3																			
	G/F																				
	1/F																				
	2/F																				
	3/F																				
	4/F																				
	Submission of Record of Test																				
3.8	Noise & Sound Check	Clause 4.3.4																			
	G/F																				
	1/F																				
	2/F																				
	3/F																				
	4/F																				
	Submission of Record of Test																				
3.9	Vibration Check	Clause 4.3.5																			
	G/F																				
	1/F																				
	2/F																				
	3/F																				
	4/F																				
	Submission of Record of Test																				

Testing and Commissioning Certificate on Air-conditioning, Refrigeration, Ventilation and Central Monitoring & Control System Installation

Part 1: Details of Project

- 1.1 Project title (with location): _____
- 1.2 *P.W.P. / Project No.: _____
- 1.3 *Contract/Sub-contract/Quotation No.: _____
- 1.4 *Contractor/Sub-contractor: _____
- 1.5 Date of Test: _____
- 1.6 Name of PBSE: _____
- 1.7 Name of PBSI: _____

Part 2: Declaration

- 2.1 I certify that the Air-conditioning, Refrigeration, Ventilation and Central Monitoring & Control System Installation as specified in the *Contract/ Sub-contract/Quotation at the above location has been inspected, tested and commissioned in accordance with this Testing and Commissioning (T&C) Procedure (*Note 1*) and/or any other procedure(s) as agreed between the PBSE and the A/C Contractor. The results are satisfactory in the aspects as mentioned in Part 3 and/or as recorded in Part 4 of this Certificate, except as indicated in the COMMENTS item(s).
- 2.2 I also certify that site tests have been performed in accordance with the requirements set out in this T&C Procedure and that the results are satisfactory. A record of the tests has been prepared and submitted to the PBSE.

Name of A/C Contractor's Representative: _____	Signature: _____
Designation / Post of A/C Contractor's Representative: _____	Date signed: _____
Name and Stamp of A/C Contractor: _____	Telephone No.: _____

Notes

* Delete if not applicable

- (1) "T&C Procedure" refers to the Testing and Commissioning Procedure for Air-conditioning, Refrigeration, Ventilation and Central Monitoring & Control System Installation.
- (2) The A/C Contractor's Representative signing this Certificate must be a person or representative authorised by the A/C Contractor.
- (3) Plant performance can be substantiated only when the test data have been recorded and validated against the design data. Proforma for recording such data can be found in the succeeding pages and these should be properly filled in before submission to the designers with any relevant comments related to site conditions. Peak Load Test shall be carried out for the entire system with test record submitted accordingly.

		Items tested/ checked by <u>A/C Contractor</u>	Items witnessed by <u>PBSE/PBSI</u>
Part 3: <u>Items Inspected and Tested</u>			
3.1	The General Requirements as indicated in the T&C Procedure have been complied with.	*Yes/No/N.A.	*Yes/No/N.A.
3.2	Pre-commissioning Checks		
3.2.1	Water Distribution System		
(a)	The system has been properly cleaned, flushed and filled with water.	*Yes/No/N.A.	*Yes/No/N.A.
(b)	The equipment associated with the system has undergone the mechanical and electrical checks and the results are satisfactory.	*Yes/No/N.A.	*Yes/No/N.A.
3.2.2	Air Distribution System		
(a)	The system has been properly cleaned and usually checked for air tightness.	*Yes/No	*Yes/No
(b)	The equipment associated with the system has undergone mechanical and electrical checks and the results are satisfactory.	*Yes/No	*Yes/No
3.3	Setting to Work & Balancing		
3.3.1	Water Distribution System		
(a)	The water pumps have been commissioned in accordance with this T&C Procedure and the pumps are operating satisfactorily.	*Yes/No/N.A.	*Yes/No/N.A.
(b)	The water flow rates of the system have been regulated and balanced in accordance with this T&C Procedure. The results are satisfactory meeting the specified requirements.	*Yes/No/N.A.	*Yes/No/N.A.
3.3.2	Air Distribution System		
(a)	The filters have been commissioned according to *this/manufacturer's procedure and the results are satisfactory, meeting the specified requirements.	*Yes/No/N.A.	*Yes/No/N.A.
(b)	The fans have been commissioned according to *this/manufacturer's procedure and the results are satisfactory meeting the specified requirements.	*Yes/No/N.A.	*Yes/No/N.A.
(c)	The air flow rates of the system have been regulated in accordance with this T&C Procedure and the system is delivering the designed air volumes at the terminal outlets.	*Yes/No/N.A.	*Yes/No/N.A.

Tested / Checked by : (Name of A/C Contractor's Representative)	Signature - ()	Post:	
		Tel. No.:	
		Date:	
Witnessed by: (Name(s) of *PBSE/PBSI)	Signature - ()	Post:	
		Tel. No.:	
		Date:	

		Items tested/ checked by <u>A/C Contractor</u>	Items witnessed by <u>PBSE/PBSI</u>
3.3.3	Ventilation and Air-conditioning Control (VAC) interfacing with Fire Alarm Signal		
3.3.3.1	Method A		
	Compartment: _____		
	Serial/ Code No. of Fans serving the compartment : _____		
(a)	The compartment is provided with a smoke detector automatic fire alarm system.	*Yes/No/N.A.	*Yes/No/N.A.
(b)	Any smoke detector of the compartment is activated; all fans severing the compartment shall be shut down.	*Yes/No/N.A.	*Yes/No/N.A.
(c)	All fans unable to restart while fire signal exist.	*Yes/No/N.A.	*Yes/No/N.A.
(d)	Manual Override Switch shall be installed adjacent to the Fire Control Panel of the building and easy to operate.	*Yes/No/N.A.	*Yes/No/N.A.
(e)	All fans involved in the VAC system shall be shut down when Manual Override Switch is activated.	*Yes/No/N.A.	*Yes/No/N.A.
(f)	Fail Safe test for the circuit of Manual Override Switch.	*Yes/No/N.A.	*Yes/No/N.A.
(g)	Other fan shall be interlocked.	*Yes/No/N.A.	*Yes/No/N.A.
3.3.3.2	Method B		
(a)	Probe-type Smoke Detector is provided in the ductwork.	*Yes/No/N.A.	*Yes/No/N.A.
(b)	The fan shut down by probe-type smoke detector.	*Yes/No/N.A.	*Yes/No/N.A.
(c)	Fail Safe test for the circuit of probe-type detector.	*Yes/No/N.A.	*Yes/No/N.A.
(d)	The fans unable to restart while fire signal exists.	*Yes/No/N.A.	*Yes/No/N.A.
(e)	Manual Override Switch shall be installed adjacent to the Fire Control Panel of the building and easy to operate.	*Yes/No/N.A.	*Yes/No/N.A.
(f)	All fans involved in the VAC system shall be shut down when Manual Override Switch is activated.	*Yes/No/N.A.	*Yes/No/N.A.
(g)	Fail Safe test for the circuit of Manual Override Switch.	*Yes/No/N.A.	*Yes/No/N.A.
(h)	All fans serving the same compartment shall be interlocked	*Yes/No/N.A.	*Yes/No/N.A.
(i)	Other fan shall be interlocked.	*Yes/No/N.A.	*Yes/No/N.A.

Tested / Checked by : (Name of A/C Contractor's Representative)	Signature - ()	Post:	
		Tel. No.:	
		Date:	
Witnessed by: (Name(s) of *PBSE/PBSI)	Signature - ()	Post:	
		Tel. No.:	
		Date:	

		Items tested/ checked by <u>A/C Contractor</u>	Items witnessed by <u>PBSE/PBSI</u>
3.3.3.3	Method C		
(a)	All fans involved in the VAC System shall be shut down when building fire alarm system is achieved.	*Yes/No/N.A.	*Yes/No/N.A.
(b)	All fans unable to restart while fire signal exists.	*Yes/No/N.A.	*Yes/No/N.A.
(c)	Manual Override Switch shall be installed adjacent to the Fire Control Panel of the building and easy to operate.	*Yes/No/N.A.	*Yes/No/N.A.
(d)	All fans involved in the VAC System shall be shut down when Manual Override Switch is activated.	*Yes/No/N.A.	*Yes/No/N.A.
(e)	Fail Safe test for the circuit of Manual Override Switch.	*Yes/No/N.A.	*Yes/No/N.A.

Tested / Checked by : (Name of A/C Contractor's Representative)	Signature - ()	Post:	
		Tel. No.:	
		Date:	
Witnessed by: (Name(s) of *PBSE/PBSI)	Signature - ()	Post:	
		Tel. No.:	
		Date:	

		<u>Items tested/ checked by A/C Contractor</u>	<u>Items witnessed by PBSE/PBSI</u>
3.3.4	Refrigeration Systems		
3.3.4.1	The system has been satisfactorily cleaned and the equipment has undergone electrical and mechanical checks.	*Yes/No	*Yes/No
3.3.4.2	Reciprocating Compressor System		
(a)	The refrigeration system has been commissioned by a specialist in accordance with the manufacturer's recommendations.	*Yes/No/N.A.	*Yes/No/N.A.
(b)	The refrigeration system has satisfactorily completed the running-in period as specified in this T&C Procedure and all necessary adjustments/ repairs/ replacements have been carried out.	*Yes/No/N.A.	*Yes/No/N.A.
3.3.4.3	Centrifugal Compressor System (Including Oil Free Compressor)		
(a)	The refrigeration system has been commissioned by a specialist in accordance with the manufacturer's recommendations.	*Yes/No/N.A.	*Yes/No/N.A.
(b)	The refrigeration system has satisfactorily completed the running-in period as specified in this T&C Procedure and all necessary adjustments/ repairs/ replacements have been carried out.	*Yes/No/N.A.	*Yes/No/N.A.
3.3.4.4	Absorption System		
(a)	The refrigeration system has been commissioned by a specialist in accordance with the manufacturer's recommendations.	*Yes/No/N.A.	*Yes/No/N.A.
(b)	The refrigeration system has satisfactorily completed the running-in period as specified in this T&C Procedure and all necessary adjustments/ repairs/ replacements have been carried out.	*Yes/No/N.A.	*Yes/No/N.A.
3.3.4.5	Screw Compressor System		
(a)	The refrigeration system has been commissioned by a specialist in accordance with the manufacturer's recommendations.	*Yes/No/N.A.	*Yes/No/N.A.
(b)	The refrigeration system has satisfactorily completed the run-in period as specified in this T&C Procedure and all necessary adjustments/ repairs/ replacements have been carried out.	*Yes/No/N.A.	*Yes/No/N.A.
3.3.4.6	Cooling Tower		
(a)	The cooling tower(s) of the installation *has/have been field tested in accordance with this T&C Procedure and the results are satisfactory, meeting the specified requirements.	*Yes/No/N.A.	*Yes/No/N.A.

Tested / Checked by : (Name of A/C Contractor's Representative)	Signature - ()	Post:	
		Tel. No.:	
		Date:	
Witnessed by: (Name(s) of *PBSE/PBSI)	Signature - ()	Post:	
		Tel. No.:	
		Date:	

		<u>Items tested/ checked by A/C Contractor</u>	<u>Items witnessed by PBSE/PBSI</u>
3.3.5	Automatic Control System		
(a)	Audit of the cabling and hardware installation	*Yes/No	*Yes/No
(b)	All the safety devices including circuit interlocks and cut-outs have been checked for correct installation and operation.	*Yes/No	*Yes/No
(c)	Demonstration that sensors and actuators are correctly connected and addressed.	*Yes/No	*Yes/No
(d)	Demonstration of the physical and logical integrity of the system.	*Yes/No	*Yes/No
(e)	Demonstration of sensor calibrations	*Yes/No	*Yes/No
(f)	Demonstration of all control actions	*Yes/No	*Yes/No
(g)	Demonstration of successful system control commissioning and testing.	*Yes/No	*Yes/No
(h)	Verification of specified training requirements	*Yes/No	*Yes/No
(i)	Verification of handover of all specified operating manuals, documentation and drawings	*Yes/No	*Yes/No

Comments :

Tested / Checked by : (Name of A/C Contractor's Representative)	Signature - ()	Post:	
		Tel. No.:	
		Date:	
Witnessed by: (Name(s) of *PBSE/PBSI)	Signature - ()	Post:	
		Tel. No.:	
		Date:	

		<u>Items tested/ checked by A/C Contractor</u>	<u>Items witnessed by PBSE/PBSI</u>	<u>Checked by/Date</u>
3.3.6	Central Control Monitoring System			
3.3.6.1	Controller/Router/Gateway/Interfacing Unit			
(a)	"As built" drawings incorporate latest modifications	*Yes/No/N.A.	*Yes/No	
(b)	Secure door locks	*Yes/No/N.A.	*Yes/No	
(c)	Switches - location & labelling	*Yes/No/N.A.	*Yes/No	
(d)	Access for incoming/outgoing cables	*Yes/No/N.A.	*Yes/No	
(e)	Doors & gland plates earthed	*Yes/No/N.A.	*Yes/No	
(f)	Tightness of connections	*Yes/No/N.A.	*Yes/No	
(g)	20% spare capacity	*Yes/No/N.A.	*Yes/No	
(h)	Cable identification	*Yes/No/N.A.	*Yes/No	
(i)	Terminals numbered	*Yes/No/N.A.	*Yes/No	
(j)	Segregation of electronic equipment	*Yes/No/N.A.	*Yes/No	
(k)	CCMS cables – link type terminals	*Yes/No/N.A.	*Yes/No	
(l)	Labelling of equipment	*Yes/No/N.A.	*Yes/No	
3.3.6.2	Inspection Checklist for CCMS Workstation/Server			
(a)	Installation of CCMS workstation	*Yes/No/N.A.	*Yes/No	
(i)	Physical inspection of facility	*Yes/No/N.A.	*Yes/No	
(ii)	Power supply connection	*Yes/No/N.A.	*Yes/No	
(b)	CCMS workstation operation	*Yes/No/N.A.	*Yes/No	
(i)	From 'Switch On' Central reaches operational state unaided	*Yes/No/N.A.	*Yes/No	
(ii)	Central real time clock operational	*Yes/No/N.A.	*Yes/No	
(iii)	Central makes correct attempts to establish communications	*Yes/No/N.A.	*Yes/No	
(iv)	Central responds to incoming communications	*Yes/No/N.A.	*Yes/No	
(v)	Operation of peripheral equipment	*Yes/No/N.A.	*Yes/No	
(vi)	Data acquisition speed satisfactory	*Yes/No/N.A.	*Yes/No	

Tested / Checked by : (Name of A/C Contractor's Representative)	Signature - ()	Post:	
		Tel. No.:	
		Date:	
Witnessed by: (Name(s) of *PBSE/PBSI)	Signature - ()	Post:	
		Tel. No.:	
		Date:	

	<u>Items tested/ checked by A/C Contractor</u>	<u>Items witnessed by PBSE/PBSI</u>	<u>Checked by/Date</u>
(c) Central Functions	*Yes/No/N.A.	*Yes/No	
(i) Data logging routines	*Yes/No/N.A.	*Yes/No	
(ii) Control parameter update	*Yes/No/N.A.	*Yes/No	
(iii) Alarm system	*Yes/No/N.A.	*Yes/No	
(iv) Password facility	*Yes/No/N.A.	*Yes/No	
(v) Data archiving system	*Yes/No/N.A.	*Yes/No	
(vi) Reporting & monitoring functions	*Yes/No/N.A.	*Yes/No	
(vii) Graphics	*Yes/No/N.A.	*Yes/No	
(d) Commissioning successful & documented	*Yes/No/N.A.	*Yes/No	
(e) Documentation, spares & software backup	*Yes/No/N.A.	*Yes/No	
(f) Training complete	*Yes/No/N.A.	*Yes/No	
(g) Other functions	*Yes/No/N.A.	*Yes/No	

Tested / Checked by : (Name of A/C Contractor's Representative)	Signature - ()	Post:	
		Tel. No.:	
		Date:	
Witnessed by: (Name(s) of *PBSE/PBSI)	Signature - ()	Post:	
		Tel. No.:	
		Date:	

		Items tested/ checked by <u>A/C Contractor</u>	Items witnessed by <u>PBSE/PBSI</u>
3.3.7	Noise and Sound Tests		
	The noise and sound levels in areas as specified have been checked in accordance with this T&C Procedure and are found in compliance with the Specification.	*Yes/No/N.A.	*Yes/No/N.A.
3.3.8	Vibration Tests		
	The vibration tests for equipment as specified have been carried out in accordance with this T&C Procedure and the results are satisfactory, meeting the specified requirements.	*Yes/No/N.A.	*Yes/No/N.A.
3.3.9	Full-load Performance Test		
(a)	A full-load performance test has been carried out and the results, which were recorded separately, were found meeting the specified requirements.	*Yes/No/N.A.	*Yes/No/N.A.
(b)	a full-load performance test has NOT been carried out but it will be carried out during the free-maintenance period.	*Yes/No/N.A.	*Yes/No/N.A.

Tested / Checked by : (Name of A/C Contractor's Representative)	Signature - ()	Post:	
		Tel. No.:	
		Date:	
Witnessed by: (Name(s) of *PBSE/PBSI)	Signature - ()	Post:	
		Tel. No.:	
		Date:	

Items tested/
checked by
A/C Contractor

Items witnessed
by
PBSE/PBSI

*Yes/No/N.A.

*Yes/No/N.A.

3.4 Comments

Tested / Checked by : (Name of A/C Contractor's Representative)	Signature - ()	Post:	
		Tel. No.:	
		Date:	
Witnessed by: (Name(s) of *PBSE/PBSI)	Signature - ()	Post:	
		Tel. No.:	
		Date:	

Part 4: Test Results and Records**4.1 Packaged Water Chillers**

Location: _____	No.: _____	<u>Design Data</u>	<u>Test Result (full load)</u>	<u>Test Result (part load)</u>	<u>Remarks</u>
Machine Type					
Refrigerant Type					
Capacity	(kW)				
Leaving Chilled Water Temperature	(°C)				
Leaving Chilled Water Temperature control Limited	(°C)				
Entering Chilled Water Temperature	(°C)				
Chilled Water Quantity	(l/s)				
Entering Condenser Water Temperature	(°C)				
Leaving Condenser Water Temperature	(°C)				
Condenser Water Quantity	(l/s)				
Evaporator Fouling Factor			N/A	N/A	
Condenser Fouling Factor			N/A	N/A	
Evaporator Working Pressure	(kPa)				
Evaporator Test Pressure	(kPa)				
Evaporator Entering Temperature	(°C)				
Evaporator Leaving Temperature	(°C)				
Condenser Working Pressure	(kPa)				
Condenser Test Pressure	(kPa)				

Tested / Checked by : (Name of A/C Contractor's Representative)	Signature - ()	Post:	
		Tel. No.:	
		Date:	
Witnessed by: (Name(s) of *PBSE/PBSI)	Signature - ()	Post:	
		Tel. No.:	
		Date:	

4.1 Packaged Water Chillers (Cont'd)

Location: _____	No.: _____	Design Data	Test Result (full load)	Test Result (part load)	Remarks
Condenser Entering Temperature	(°C)				
Condenser Leaving Temperature	(°C)				
Motor Type					
Starting Method/Type					
Motor Speed	(rev/s)				
Motor Power	(kW)				
Starting Current	(A)				
Running Current	(A)				
Motor Power	(kW)				
Overload Current	(A)				
Tripping Time of Starter Overload	(S)				
Motor Full-load Condition	(amp. & volt)				
Motor No-load Condition	(amp. & volt)				
Drive Arrangement					
Machine Mountings					
Supply Voltage	(V)				
Index of Protection	(IP)				
Emergency Stop					

Note: The A/C Contractor shall carry out full load and part load (40% ~ 60% of full load) tests of the chillers at different seasons separately.

Tested / Checked by : (Name of A/C Contractor's Representative)	Signature - ()	Post:	
		Tel. No.:	
		Date:	
Witnessed by: (Name(s) of *PBSE/PBSI)	Signature - ()	Post:	
		Tel. No.:	
		Date:	

4.2 Air-Cooled Chillers

Location: _____ No.: _____ Design Data Test Result (full load) Test Result (part load) Remarks

Compressor

Refrigerant Type

Capacity (kW)

Saturated Suction Temperature (°C)

Saturated Discharge Temperature (°C)

Total Heat Rejected (kW)

Compressor Absorbed Power (kW)

Motor Nameplate Rating (kW)

Motor Type

Motor Speed (rev/s)

Drive

Motor Full-load Condition (amp. & volt)

Motor No-load Condition (amp. & volt)

Supply Voltage (V)

Starting Current (A)

Running Current (A)

Emergency Stop

Condenser

Capacity (kW)

Condensing Temperature (°C)

Summer Design External Dry Bulb (°C)

Sub-cooling (°C)

Head Pressure Control Method

Fan Type

Drive

Tested / Checked by : (Name of A/C Contractor's Representative)	Signature - ()	Post:	
		Tel. No.:	
		Date:	
Witnessed by: (Name(s) of *PBSE/PBSI)	Signature - ()	Post:	
		Tel. No.:	
		Date:	

4.2 Air-Cooled Chillers (Cont'd)

Location: _____	No.: _____	<u>Design Data</u>	<u>Test Result (full load)</u>	<u>Test Result (part load)</u>	<u>Remarks</u>
Motor Type					
Motor Nameplate Rating	(kW)				
Motor Speed	(rev/s)				
Motor Full-load Condition	(amp. & volt)				
Motor No-load Condition	(amp. & volt)				
Supply Voltage	(V)				
High Pressure Cut-in	(kPa)				
High Pressure Cut-out	(kPa)				
Low Pressure Cut-in	(kPa)				
Low Pressure Cut-out	(kPa)				
Oil Pressure Cut-out	(kPa)				
Motor High Temperature Cut-out	(°C)				
Freeze up Temperature Cut-out	(°C)				
Flow Switch Cutout	(l/s)				
Anti-Recycle Logic					
Bad Phase Protection					
Under Voltage Protection					
Emergency Stop					
Condensate Fan Start-up Sequencing					

Tested / Checked by : (Name of A/C Contractor's Representative)	Signature - ()	Post:	
		Tel. No.:	
		Date:	
Witnessed by: (Name(s) of *PBSE/PBSI)	Signature - ()	Post:	
		Tel. No.:	
		Date:	

4.3 Cooling Towers

Location: _____	No.: _____	Design Data	Test Result (full load)	Test Result (part load)	Remarks
Type : _____					
Cooling Capacity	(kW)				
Summer Design Wet Bulb Temperature	(°C)				
Altitude above Sea Level	(m)				
Entering Dry Bulb Temperature	(°C)				
Entering Wet Bulb Temperature	(°C)				
Leaving Dry Bulb Temperature	(°C)				
Leaving Wet Bulb Temperature	(°C)				
Make-up water Quantity	(l/s)				
Constant Bleed Water Quantity	(l/s)				
Cooling Water Flow Rate	(l/s)				
Cooling Water Entering Temperature	(°C)				
Cooling Water Leaving Temperature	(°C)				
Fan Type					
Fan Outlet Size	(m ²)				
Fan Volume	(l/s)				
Fan Drive					
Motor Type					
Motor Speed	(rev/s)				
Motor Rating	(kW)				
Tower Water Connections Diameter	(mm)				
Balance Pipe Connection Diameter	(mm)				
Supply Voltage	(V)				
Starting Current	(A)				
Running Current	(A)				
Emergency Stop					

Tested / Checked by : (Name of A/C Contractor's Representative)	Signature - ()	Post:	
		Tel. No.:	
		Date:	
Witnessed by: (Name(s) of *PBSE/PBSI)	Signature - ()	Post:	
		Tel. No.:	
		Date:	

4.4 Pumps

Location: _____	No.: _____	Design Data	Test Result (full load)	Test Result (part load)	Remarks
Volume Flow Rate	(l/s)				
No Flow Head	(kPa)				
Full Flow Discharge Head	(kPa)				
Full Suction Pressure	(kPa)				
Full Flow Differential	(kPa)				
Impeller Diameter	(mm)				
Motor Type					
Motor Speed	(rev/s)				
Rated Power	(kW)				
Motor Full-load Condition	(amp. & volt)				
Supply Voltage	(V)				
Starting Current	(A)				
Running Current	(A)				
Overload Setting	(A)				
Tripping Time of Starter Overload	(S)				
Auto-changeover			*Yes/No/N.A.	*Yes/No/N.A.	
Emergency Stop			*Yes/No/N.A.	*Yes/No/N.A.	
Low Level Cut-in			*Yes/No/N.A.	*Yes/No/N.A.	
Low Level Cut-out			*Yes/No/N.A.	*Yes/No/N.A.	
High Level Cut-out			*Yes/No/N.A.	*Yes/No/N.A.	
Horn Buzzer			*Yes/No/N.A.	*Yes/No/N.A.	
Lamp Test Button			*Yes/No/N.A.	*Yes/No/N.A.	
Degree of Protection of Enclosures (IP)			*Yes/No/N.A.	*Yes/No/N.A.	

Tested / Checked by : (Name of A/C Contractor's Representative)	Signature - ()	Post:	
		Tel. No.:	
		Date:	
Witnessed by: (Name(s) of *PBSE/PBSI)	Signature - ()	Post:	
		Tel. No.:	
		Date:	

4.5 Pump Alignment Test

Location: _____

Ref. No.: _____

	Rim Check Reading				Face Check Reading			
	T	B	L	R	T	B	L	R
Pump No.								
Pump No.								
Pump No.								
Pump No.								

Remarks:

T : Top Reading

B : Bottom Reading

L : Left Hand Side Reading

R : Right Hand Side Reading

Maximum allowable misalignments refer to the recommendation in the General Specification or Manufacture's Recommendation.

Tested / Checked by : (Name of A/C Contractor's Representative)	Signature - ()	Post:	
		Tel. No.:	
		Date:	
Witnessed by: (Name(s) of *PBSE/PBSI)	Signature - ()	Post:	
		Tel. No.:	
		Date:	

4.6 Air Handling Units

Location: _____	No.: _____	Design Data	Test Result (full load)	Test Result (part load)	Remarks
Outdoor Air Condition					
Dry Bulb Temperature	(°C)				
Wet Bulb Temperature	(°C)				
Time of Day	(Hrs)				
Condition	(Cloudy/Sunny)				
Total Air Quantity	(l/s)				
Fresh Air Quantity (Minimum)	(l/s)				
Fresh Air Quantity (Maximum)	(l/s)				
Smoke Detector			*Yes/No/N.A.	*Yes/No/N.A.	
Fan					
Type					
Speed	(r/s)				
Drive					
Driven Belt (Type/No.)					
Inlet pressure	(kPa)				
Discharge pressure	(kPa)				
Fan Static Pressure (Discharge - Inlet)	(kPa)				
Supply Voltage	(V)				
Overload Setting	(A)				
Tripping Time of Overload	(S)				
Starting Current	(A)				
Running Current	(A)				
Rated Power	(kW)				
Emergency Stop					

Tested / Checked by : (Name of A/C Contractor's Representative)	Signature - ()	Post:	
		Tel. No.:	
		Date:	
Witnessed by: (Name(s) of *PBSE/PBSI)	Signature - ()	Post:	
		Tel. No.:	
		Date:	

4.6 Air Handling Units (Cont'd)

Location: _____ No.: _____ Design Data Test Result (full load) Test Result (part load) Remarks

Filter

Type :

Inlet Pressure (kPa)

Outlet Pressure (kPa)

Effective Area (m²)

Velocity (m/s)

Cleanliness

Alarm Buzzer

Filter Clogged Light

Cooling Coil

Entering Air Dry Bulb Temperature (°C)

Entering Air Wet Bulb Temperature (°C)

Leaving Air Dry Bulb Temperature (°C)

Leaving Air Wet Bulb Temperature (°C)

Entering Water Temperature (°C)

Leaving Water Temperature (°C)

Entering Water Pressure (kPa)

Leaving Water Pressure (kPa)

Water Quantity (l/s)

Evaporator Suction Pressure (kPa)

Evaporator Suction Temperature (°C)

Evaporator Discharge Pressure (kPa)

Evaporator Discharge Temperature (°C)

Effective Area (m²)

Velocity (m/s)

Tested / Checked by : (Name of A/C Contractor's Representative)	Signature - ()	Post:	
		Tel. No.:	
		Date:	
Witnessed by: (Name(s) of *PBSE/PBSI)	Signature - ()	Post:	
		Tel. No.:	
		Date:	

4.6 Air Handling Units (Cont'd)

Location: _____	No.: _____	Design Data	Test Result (full load)	Test Result (part load)	Remarks
Heating Coil (Medium)					
Entering Air Dry Bulb Temperature	(°C)				
Leaving Air Dry Bulb Temperature	(°C)				
Effective Area	(m ²)				
Velocity	(m/s)				
Entering Water Temperature	(°C)				
Leaving Water Temperature	(°C)				
Entering Water Pressure	(kPa)				
Leaving Water Pressure	(kPa)				
Water Quantity	(l/s)				
No. of steps					
Capacity of Each Steps	(kW)				
Air Quantity	(l/s)				

Tested / Checked by : (Name of A/C Contractor's Representative)	Signature - ()	Post:	
		Tel. No.:	
		Date:	
Witnessed by: (Name(s) of *PBSE/PBSI)	Signature - ()	Post:	
		Tel. No.:	
		Date:	

4.7 Heating Coils (Not included in Air Handling Unit)

Location: _____	No.: _____	Design Data	Test Result (full load)	Test Result (part load)	Remarks
Medium					
Entering Air Dry Bulb Temperature	(°C)				
Leaving Air Dry Bulb Temperature	(°C)				
Effective Area	(m ²)				
Velocity	(m/s)				
Air Quantity	(l/s)				
Entering Water Pressure	(kPa)				
Leaving Water Pressure	(kPa)				
Water Quantity	(l/s)				
Capacity of Coil	(kW)				
No. of Steps					
Capacity of Each Step	(kW)				

Tested / Checked by : (Name of A/C Contractor's Representative)	Signature - ()	Post:	
		Tel. No.:	
		Date:	
Witnessed by: (Name(s) of *PBSE/PBSI)	Signature - ()	Post:	
		Tel. No.:	
		Date:	

4.8 Ducts, Grilles, Diffusers, etc.

Location: _____ No.: _____ Design Data Test Result (full load) Test Result (part load) Remarks

Air flow rate _____ (l/s)

Access Panel for maintenance provided *Yes/No/N.A. *Yes/No/N.A.

Use the air flow sheets and indicate the design and test figures as indicated in Annex V Section 2.

Tested / Checked by : (Name of A/C Contractor's Representative)	Signature - ()	Post:	
		Tel. No.:	
		Date:	
Witnessed by: (Name(s) of *PBSE/PBSI)	Signature - ()	Post:	
		Tel. No.:	
		Date:	

4.9 Pressure Test

(Remark: After replacement or repair of the compressor/refrigeration system work, this test shall be carried out.)

Location: _____

Ref. No.: _____

Refrigerant	High Side Test Pressure, kPa		Low Side Test Pressure, kPa	
	Specification Requirement	Test Result	Specification Requirement	Test Result
R22 (Air-cooled)				
R22 (Water-cooled)				
R134a (Air-cooled)				
R134a (Water-cooled)				
Others				

In performing pressure test for refrigerant system and circuit containing blend refrigerant, e.g. R407C and R410a, manufacturer's recommended procedures and test pressure shall be followed.

Tested / Checked by : (Name of A/C Contractor's Representative)	Signature - ()	Post:	
		Tel. No.:	
		Date:	
Witnessed by: (Name(s) of *PBSE/PBSI)	Signature - ()	Post:	
		Tel. No.:	
		Date:	

4.10 Evacuation Test

(Remark: The evacuation shall be pulled down to between absolute pressure of 170 Pa and 340 Pa)

Location: _____

Ref. No.: _____

1 st Duration of Test 4 hours				
2 nd Duration of Test 3 hours				
3 rd Duration of Test 2 hours				
Refrigerant Type:				

Tested / Checked by : (Name of A/C Contractor's Representative)	Signature - ()	Post:	
		Tel. No.:	
		Date:	
Witnessed by: (Name(s) of *PBSE/PBSI)	Signature - ()	Post:	
		Tel. No.:	
		Date:	

4.11 Air Duct Leakage Test Sheet

Project Title (with location) _____
 Programme NO. _____
 * Contract/Sub-contract/Quotation No. _____
 Date of Test _____
 Type, Model & Serial No. of Instrument used _____
 Date of Calibration _____

Part 1 – Physical Details

- (i) Section of ductwork to be test _____
 (ii) Surface area of duct under test _____
 (iii) Test static pressure _____
 (iv) Leakage factor _____
 (v) Maximum permitted leakage
 (b x d) _____

Part 2 – Test Particulars

- (i) Duct static pressure reading _____
 (ii) Type of flow measuring device _____
 (iii) Range of measurement of flow
 measuring device _____
 (iv) Reading of flow measuring device _____
 (v) Interpreted air flow leakage rate _____
 (vi) Duration of test (normally 15
 minutes) _____

Length, mm	Width and Depth or Diameter, mm	Periphery, mm	Area, mm ²
Total			

Tested / Checked by : (Name of A/C Contractor's Representative)	Signature - ()	Post:	
		Tel. No.:	
		Date:	
Witnessed by: (Name(s) of *PBSE/PBSI)	Signature - ()	Post:	
		Tel. No.:	
		Date:	

4.12 Fan Coil Unit

Location: _____
 No.: _____

Description:	Design Result	Test Result	Remarks
Manufacturer			
Model No.			
Serial No.			
Country of Origin			
Motor Type			
Supply Voltage (V)			
Rated Power (kW)			
Cooling Coil Valve Operate in Normal Condition			*Yes/No/N.A.
No. of Blower(s)			
Air Flow Rate (l/s)			
Water Flow Rate (l/s)			
Chilled Water Entering Temperature (°C)			
Chilled Water Leaving Temperature (°C)			
Hot Water Entering Temperature – if any (°C)			
Hot Water Leaving Temperature – if any (°C)			
Supply Air Temperature (°C)			
Return Air Temperature (°C)			
Heating Element (°C)			
Electric Heater (°C)			
Maximum Output Power (kW)			
Overheat Cut-off Operate within 90sec at 50°C ±10%			*Yes/No/N.A.
Air Flow Switch			*Yes/No/N.A.
Manual Reset Switch Installed			*Yes/No/N.A.
Warning Label Provided			*Yes/No/N.A.
A Small Hole Provided for Inserting a Testing Thermometer			*Yes/No/N.A.
Heater and Blower Interlock			*Yes/No/N.A.
No Internal Insulation within 1m from Heater			*Yes/No/N.A.
Assess Panel for Maintenance Provided			*Yes/No/N.A.
Warning Label Provided			*Yes/No/N.A.

Tested / Checked by : (Name of A/C Contractor's Representative)	Signature - ()	Post:	
		Tel. No.:	
		Date:	
Witnessed by: (Name(s) of *PBSE/PBSI)	Signature - ()	Post:	
		Tel. No.:	
		Date:	

4.13 Variable Air Volume (VAV) Box

Location: _____
 No.: _____

Description:	Design Result	Test Result	Remarks
Manufacturer			
Model No.			
Serial No.			
Country of Origin			
Air Flow Rate (l/s)			
Pressure (kPa)			
Supply Air Temperature (°C)			
Air Flow Control Damper operate in Normal Condition			*Yes/No/N.A.
CCMS Control in Normal Condition			*Yes/No/N.A.
Electric Heater			
Output Power (kW)			
Temperature (°C)			
Maximum Current (A)			
Overheat Cut-off Operate within 90sec at 50°C ±10%			*Yes/No/N.A.
Air Flow Switch			*Yes/No/N.A.
Manual Reset Switch Installed			*Yes/No/N.A.
Warning Label Provided			*Yes/No/N.A.
Heater and Blower Interlock			*Yes/No/N.A.
No Internal Insulation within 1m from Heater			*Yes/No/N.A.
Emergency Stop Provided			*Yes/No/N.A.
Assess Panel for Maintenance			*Yes/No/N.A.
Assess Panel Provided			*Yes/No/N.A.

Tested / Checked by : (Name of A/C Contractor's Representative)	Signature - ()	Post:	
		Tel. No.:	
		Date:	
Witnessed by: (Name(s) of *PBSE/PBSI)	Signature - ()	Post:	
		Tel. No.:	
		Date:	

4.14 Split type Air-conditioning Unit

Location: _____

No.: _____

Description:	Design Result	Test Result	Remarks
Manufacturer			
Model No. (Indoor Unit)			
Serial No.			
Model No. (Outdoor Unit)			
Serial No.			
Country of Origin			
Supply Fuse			
Control Fuse			
Compressor Rated Current (A)			
Condenser Fan Rated Current (A)			
Evaporator Fan Rated Current (A)			
Cooling Capacity			
Overload Setting			
Refrigerant Type			
Starting Current (A)			
Running Current (A)			
High Pressure Cut-out (kPa)			
Low Pressure Cut-out (kPa)			
Compressor Suction Pressure (kPa)			
Compressor Discharge Pressure (kPa)			
Evaporator Entering Coil Dry Bulb Temperature (DB-°C)			
Evaporator Entering Coil Wet Bulb Temperature (WB-°C)			
Evaporator Leaving Coil Dry Bulb Temperature (DB-°C)			
Evaporator Leaving Coil Wet Bulb Temperature (WB-°C)			
Condenser Entering Coil Dry Bulb Temperature (DB-°C)			
Condenser Entering Coil Wet Bulb Temperature (WB-°C)			
Condenser Leaving Coil Dry Bulb Temperature (DB-°C)			
Condenser Leaving Coil Wet Bulb Temperature (WB-°C)			
Emergency Stop			
Pressure Gauge(s) Installed			*Yes/No/N.A.

Tested / Checked by : (Name of A/C Contractor's Representative)	Signature - ()	Post:	
		Tel. No.:	
		Date:	
Witnessed by: (Name(s) of *PBSE/PBSI)	Signature - ()	Post:	
		Tel. No.:	
		Date:	

4.14 Split type Air-conditioning Unit(Cont'd)

Pressure Test – (Refer to the General Specification)

Refrigerant	High Side Test Pressure, kPa		Low Side Test Pressure, kPa	
	General Specification Requirement	Test Result	General Specification Requirement	Test Result
R22 (Air-cooled)	2950		1780	
R22 (Water-cooled)	1900		1360	
R134a (Air-cooled)	2080		1190	
R134a (Water-cooled)	1270		880	
Others				

In performing pressure test for refrigerant system and circuit containing blend refrigerant, e.g. R407C and R410a, manufacturer's recommended procedures and test pressure shall be followed.

Evacuation Test - (Remark: The evacuation shall be pulled down to between absolute pressure of 170 Pa and 340 Pa)- Refer to the General Specification				
1 st Duration of Test 4 hours				
2 nd Duration of Test 3 hours				
3 rd Duration of Test 2 hours				
Refrigerant Type:				

Tested / Checked by : (Name of A/C Contractor's Representative)	Signature - ()	Post:	
		Tel. No.:	
		Date:	
Witnessed by: (Name(s) of *PBSE/PBSI)	Signature - ()	Post:	
		Tel. No.:	
		Date:	

4.15 Variable Refrigerant Volume (VRV) System

Manufacturer:	Location	
Air Distribution System:		
Pressure testing of pipe servicing system or any section of a completed system, shall be completed prior to the application of any thermal insulation to the cleaned pipe surfaces. The pressure test for this system is recommended by the Manufacturer's.	*Yes/No/N.A	*Yes/No/N.A
The system is required to vacuum by a vacuum pump.	*Yes/No/N.A	*Yes/No/N.A
Add the refrigerant to the indoor unit through the refrigerant pipe.	*Yes/No/N.A	*Yes/No/N.A
The refrigerant is extracted by the new vacuum pump.	*Yes/No/N.A	*Yes/No/N.A

Refrigerant	High Side Test Pressure, kPa		Low Side Test Pressure, kPa	
	General Specification Requirement	Test Result	General Specification Requirement	Test Result
R22 (Air-cooled)	2950		1780	
R22 (Water-cooled)	1900		1360	
R134a (Air-cooled)	2080		1190	
R134a (Water-cooled)	1270		880	
Others				

In performing pressure test for refrigerant system and circuit containing blend refrigerant, e.g. R407C and R410a, manufacturer's recommended procedures and test pressure shall be followed.

Evacuation Test - (Remark: The evacuation shall be pulled down to between 170 Pa absolute and 340 Pa absolute)- Refer to the General Specification				
1 st Duration of Test 4 hours				
2 nd Duration of Test 3 hours				
3 rd Duration of Test 2 hours				
Refrigerant Type:				

Tested / Checked by : (Name of A/C Contractor's Representative)	Signature - ()	Post:	
		Tel. No.:	
		Date:	
Witnessed by: (Name(s) of *PBSE/PBSI)	Signature - ()	Post:	
		Tel. No.:	
		Date:	

4.15 Variable Refrigerant Volume (VRV) System (Cont'd)

Description:	Design Data	Test Result	Remark
Operating Voltage (V)			
Capacity (kW)			
Compressor Operating Current (A)			
Evaporator Operating Current (A)			
Discharge Pressure (kPa)			
Suction Pressure (kPa)			
Discharge Gas Temperature (°C)			
Heat Exchanger Liquid Pipe Temperature (°C)			
Emergency Stop Operation			
High Pressure Cut-out (kPa)			
Low Pressure Cut-out (kPa)			
Frequency Inverter (Hz)			
Outdoor Fan Step			
Outdoor Unit Expansion Valve Opening			
Indoor Unit (Unit No.) (Unit No.)			
Expansion Valve Opening			
Heat Exchanger Liquid Pipe Temperature (°C)			
Discharge Gas Temperature (°C)			
Intake Air Temperature (°C)			
Outlet Air Temperature (°C)			
Capacity (kW)			
Return Air Temperature (°C)			
Supply Air Temperature (°C)			
Room Air Temperature (°C)			
Air Flow Rate (l/s)			

Tested / Checked by : (Name of A/C Contractor's Representative)	Signature - ()	Post:	
		Tel. No.:	
		Date:	
Witnessed by: (Name(s) of *PBSE/PBSI)	Signature - ()	Post:	
		Tel. No.:	
		Date:	

4.16 Water Scrubbers

Location: _____

No.: _____

Description:	Design Data	Test Result			Remark
Manufacturer					
Model No.					
Serial No.					
Country of Origin					
Supply Voltage					
Centrifugal Fan					
Motor Power (kW/hp)					
Overload Setting (A)					
Starting Current (A)					
Running Current (A)					
Motor Speed (r.p.m.)					
Fan Speed (r.p.m.)					
Circulating Pump					
Motor Power (kW/hp)		No.1	No.2	No.3	
Overload Setting (A)					
Starting Current (A)					
Running Current (A)					
Pump Head Pressure (kPa/Bar)					
Pump Flow Rate (l/s)					
pH Meter / Sensor					
Set Point					
Alarm					
ORP Meter / Sensor					*Yes/No/N.A.
Set Point (mV)					
Alarm					
Chemical Dosing Pumps operate in normal condition					*Yes/No/N.A.
Scrubber					
Scrubber High level sensor interlock with water supply valve					*Yes/No/N.A.
Scrubber Low level sensor interlock with circulating pump					*Yes/No/N.A.
Chemical Tank Low Level Sensor interlock with Chemical Pump					*Yes/No/N.A.

Tested / Checked by : (Name of A/C Contractor's Representative)	Signature - ()	Post:	
		Tel. No.:	
		Date:	
Witnessed by: (Name(s) of *PBSE/PBSI)	Signature - ()	Post:	
		Tel. No.:	
		Date:	

4.16 Water Scrubbers(Cont'd)

Sampling Odour Test

Date of Test: _____

Location: _____

Description:	Design Data	Test Result	Remark
Chemical Weight (Na ₂ S) (g)			
Volume of H ₂ SO ₄ (ml)			
Sample Inlet			
Initial time for sampling			
Final time for sampling			
Total sampling time (Min)			
Pump Flow Rate (l/ min)			
Volume of absorbent used (ml)			
Sample Outlet			
Initial time for sampling			
Final time for sampling			
Total sampling time (min)			
Pump Flow Rate (l/ min)			
Volume of absorbent used (ml)			

Sampling Oil Mist Test

Date of Test: _____

Location: _____

Description:	Design Data	Test Result	Remark
Weight of Oil used (g)			
Pumping Rate (g/min)			
Sample Inlet			
Initial time for sampling			
Final time for sampling			
Total sampling time (min)			
Pump Flow rate (l/ min)			
Sample Outlet			
Initial time for sampling			
Final time for sampling			
Total sampling time (min)			
Pump Flow rate (l/ min)			

Tested / Checked by : (Name of A/C Contractor's Representative)	Signature - ()	Post:	
		Tel. No.:	
		Date:	
Witnessed by: (Name(s) of *PBSE/PBSI)	Signature - ()	Post:	
		Tel. No.:	
		Date:	

4.17 Exhaust Hood

Location: _____

No.: _____

Description:	Design Data	Test Result	Remark
Water Circuit Cycle Time			
Fresh-supply Water Inlet Time			
Detergent Inlet Time			
Pump Outlet Pressure			
Working Performance		*Satisfactory / Failed	
Mounting Fixture			
Water Seepage		*Satisfactory / Failed	
Indication Lighting			

Description:	Design Data	Test Result	Remark
Manufacturer:			
Model No.:			
Serial No.:			
Country of origin:			
Air Flow Rate (m ³ /s)			
Static Pressure (N/m ²)			
Exhaust Hood			
Material:			
Size (L x W x H) (mm)			
Pressure Loss (kPa)			
Main Fold & Jet Spray Nozzle			
Material:			
Number of nozzle:			
Flow Rate (l/s)			
Rotating Baffle			
Material:			
Number of baffle:			
Size: (mm)			
Control Panel			
Control:			
Control Fuse Rating:			
Number of Control Fuse:			
Control Function Indication Lamp & Fault Alarm Buzzer Provided	*Yes/No/N.A.	*Yes/No/N.A.	
Circulating Pump			
Model:			
Serial No.:			
Type:			
Casing Material:			

Tested / Checked by : (Name of A/C Contractor's Representative)	Signature - ()	Post:	
		Tel. No.:	
		Date:	
Witnessed by: (Name(s) of *PBSE/PBSI)	Signature - ()	Post:	
		Tel. No.:	
		Date:	

4.17 Exhaust Hood(Cont'd)

Description:	Design Data	Test Result	Remark
Impeller Material:			
Shaft Material:			
Flow Rate (l/s):			
Pressure Head (kPa)			
Speed/Revolution (r.p.m.)			
Pump Motor Power (kW):			
Type of Drive:			
Supply Voltage (V)			
Starting Current (A)			
Running Current (A)			
Power (kW)			
Efficiency (%)			
Overload Tripping Setting (A)			
Emergency Stop			
Detergent			
Manufacturer/Trade Mark:			
Chemical Composition:			
Detergent Capacity/each (L)			
Grease Filter			
Manufacturer			
Model:			
Type:			
Size (L x W x Thick) (mm)			
Grease Extraction Efficiency (%)			
Face Velocity (m/s)			
Pressure Drop (kPa)			
Exhaust Fan			
Manufacturer:			
Model No.:			
Serial No.:			
Country of origin:			
Supply Voltage (V)			
Motor Power (kW/hp)			
Overload Setting (A)			
Starting Current (A)			
Running Current (A)			
Motor Speed (r.p.m.)			
Emergency Stop	*Yes/No/N.A.	*Yes/No/N.A.	
Others			
Make-up water tank size (m ³ or litre)			
All valve is/are open	*Yes/No/N.A.	*Yes/No/N.A.	
Waste oil is through a Grease / treatment tank to floor drain	*Yes/No/N.A.	*Yes/No/N.A.	

Tested / Checked by : (Name of A/C Contractor's Representative)	Signature - ()	Post:	
		Tel. No.:	
		Date:	
Witnessed by: (Name(s) of *PBSE/PBSI)	Signature - ()	Post:	
		Tel. No.:	
		Date:	

4.18 Ventilation and Air-conditioning (VAC) Control Systems interfacing with Fire Alarm Signal

Description:	Design Data	Test Result	Remark
Ventilation and Air conditioning Control Systems Method A / B / C			
Location of Fan / FCU/ AHU serving the compartment / Building			
Location of Probe-type smoke Detector			
Number of Fan / FCU/ AHU serving the compartment / Building			
Emergency Stop			
Air Flow Rate (l/s)	*Yes/No/N.A.		
Fan / AHU / FCU unable to start while fire signal exist	*Yes/No/N.A.		
As indicated Fail / defect / equipment	*Yes/No/N.A.		

Details refer to BSB Fire Services T&C Procedure:

Method of overriding control (Refer to relevant requirements in the latest COP for Minimum Fire Service Installations & Equipment): Method A/B//C/combination of

Tested / Checked by : (Name of A/C Contractor's Representative)	Signature - ()	Post:	
		Tel. No.:	
		Date:	
Witnessed by: (Name(s) of *PBSE/PBSI)	Signature - ()	Post:	
		Tel. No.:	
		Date:	

4.19 Outdoor Air Pre-conditioner (OAP)

Location: _____

No.: _____

Description:	Design Data	Test Result	Remark
Manufacturer:			
Model No.:			
Serial No.:			
Motor Supply Voltage (V)			
Running Current (A)			
Supply fuse (A)			
Total Air Flow Rate (l/s)			
Supply Air Flow Rate (l/s)			
Return Air Flow Rate (l/s)			
(a) Outdoor Intake Temperature (°c)			
(b) Indoor Intake Temperature (°c)			
(c) Exchanged Air Temperature (°c)			
(d) Indoor Exhaust Temperature (°c)			

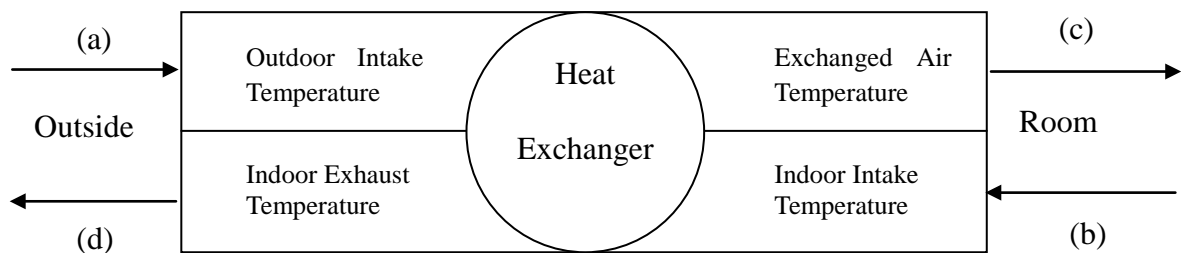

Outdoor Air Pre-conditioner

Tested / Checked by : (Name of A/C Contractor's Representative)	Signature - ()	Post:	
		Tel. No.:	
		Date:	
Witnessed by: (Name(s) of *PBSE/PBSI)	Signature - ()	Post:	
		Tel. No.:	
		Date:	

4.20 Noise & Sound Test

4.20.1 Indoor Noise Level Measurement Record

Name of Project : _____

Measuring Instrument used : _____

Model No.: _____

Serial No.: _____

Last date of calibration: _____

Date & time of measurement : _____

Measured by : _____

Weather Conditions : _____

Location of measurements (at 1.5m above floor level)	Sound Pressure Level in dB								Overall dB	NC Level
	Octave Band Centre Frequency (Hz)									
	63	125	250	500	1k	2k	4k	8k		

Observations/Remarks:

Attachments include: (1) NC curves for individual location; (2) floor layout plan indicating locations of noise measurements

Tested / Checked by : (Name of A/C Contractor's Representative)	Signature - ()	Post:	
		Tel. No.:	
		Date:	
Witnessed by: (Name(s) of *PBSE/PBSI)	Signature - ()	Post:	
		Tel. No.:	
		Date:	

4.20 Noise & Sound Test(Cont'd)

4.20.2 Outdoor Noise Level Measurement Record

Name of Project : _____

Measuring Instrument used : _____ Model No.: _____

Serial No.: _____

Last date of calibration: _____

Date & time of measurement : _____

Measured by : _____

Weather Conditions : _____

Description of Noise Source	Position of Measurement made	Time	$L_{eq,30\text{ mins}}$ in dB(A)*	Correction for Tonality, Impulsiveness and/or Intermittency according to the TM	Observations /Remarks

* The measurement shall be made over any 30-minute period according to the Technical Memorandum for the Assessment of Noise from Places other than Domestic Premises, Public Places or Construction Sites (TM) issued by the Environmental Protection Department (EPD). Measurement can be made over any shorter period when the EPD is satisfied that the noise under investigation is essentially steady over a 30-minute period.

Attachments include: (1) calibration results of the measuring instrument; (2) site plan indicating locations of noise source & noise level measuring point(s)

Tested / Checked by : (Name of A/C Contractor's Representative)	Signature - ()	Post:	
		Tel. No.:	
		Date:	
Witnessed by: (Name(s) of *PBSE/PBSI)	Signature - ()	Post:	
		Tel. No.:	
		Date:	

4.21 Vibration Test – Equipment Vibration Measurement Record

Name of Project : _____
 Measuring Instrument used : _____ Model No.: _____
 Serial No.: _____
 Last date of calibration: _____

Date & time of measurement : _____

Measured by : _____

Weather Conditions : _____

Equipment	Indicated operation speed (rev/s)		Measured speed (rev/s)		Visual/ audible check	Vibration acceptance criteria (mm/s)	Vibration measured (mm/s)			Other observations/ remarks
	Motor	Equipment	Motor	Equipment			Horizontal	Vertical	Axial	

Attachment includes a sketch showing the positions of measuring points for each equipment.

Tested / Checked by : (Name of A/C Contractor's Representative)	Signature - ()	Post :	
		Tel. No. :	
		Date :	
Witnessed by: (Name(s) of *PBSE/PBSI)	Signature - ()	Post :	
		Tel. No. :	
		Date :	

4.22 Room Temperature Record – Handover/ Peak Load /Wet & Humidity Season/ Expiry of Maintenance Period

Name of Project : _____

Measuring Instrument used : _____ Model No.: _____

Serial No.: _____

Last date of calibration: _____

Date & time of measurement : _____

Measured by : _____

Weather Conditions

Dry Bulb Temp (°C) : _____ Wind Speed (m/s) : _____

Wet Bulb Temp (°C) : _____ Atmospheric Pressure (kPa) : _____

Floor	Room No.:	Point No.:	Dry Bulb Temp.(°C)	Wet Bulb Temp.(°C)	R.H.(%) (From Chart or Calculation)
1/F	Room 1	A			
		B			
		C			
		D			
		E			
1/F	Room 2	A			
		B			
		C			
		D			
		E			

Observations/Remarks:

Attachments include: (1) test certificate of measuring instrument (if any);(2) site floor layout plan indicating locations of temperature measurements; (3) measuring point shall be indicate on attached layout plan; (4) numbering of points to be agreed by PBSE/PBSI.

Tested / Checked by : (Name of A/C Contractor's Representative)	Signature - ()	Post:	
		Tel. No.:	
		Date:	
Witnessed by: (Name(s) of *PBSE/PBSI)	Signature - ()	Post:	
		Tel. No.:	
		Date:	

4.22 Room Temperature Record – Handover/ Peak Load /Wet & Humidity Season/ Expiry of Maintenance Period (Cont'd)

Example :1/F Layout Plan

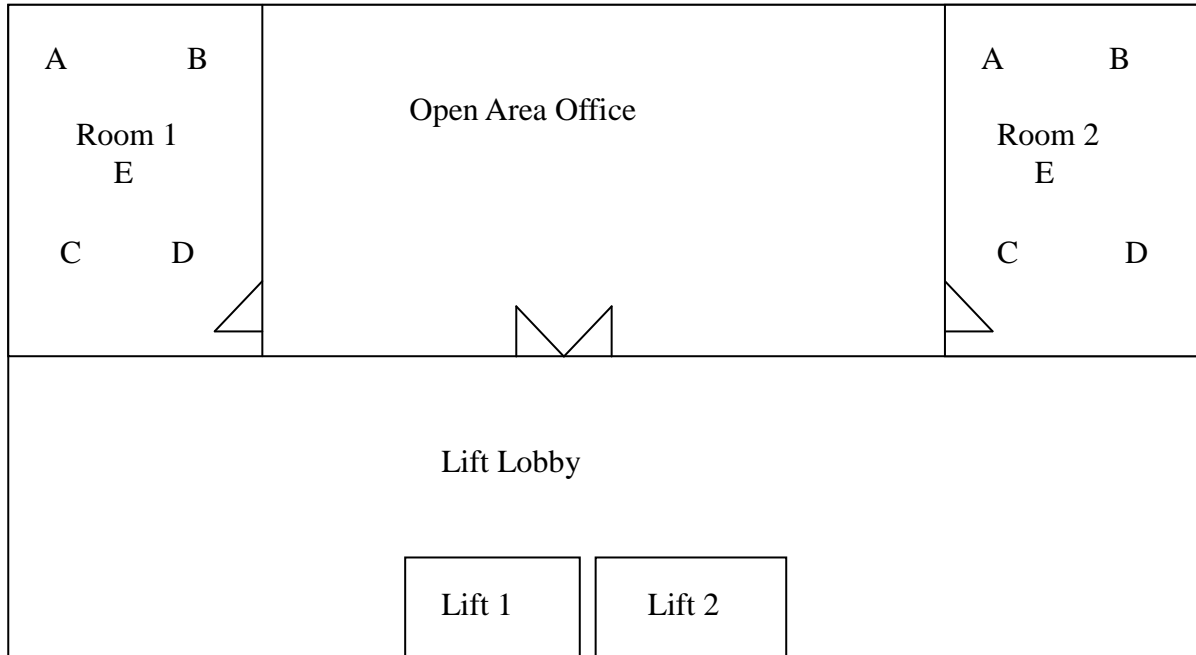

Tested / Checked by : (Name of A/C Contractor's Representative)	Signature - ()	Post:	
		Tel. No.:	
		Date:	
Witnessed by: (Name(s) of *PBSE/PBSI)	Signature - ()	Post:	
		Tel. No.:	
		Date:	

4.23 Solar Water Heating System

Location: _____

No: _____

Description	Designed Data	Test Results	Remarks
<u>Visual Inspections</u>			
Pipe Work Pressure Test Records Acceptable		(Yes/No)	
Panels Securely Fixed on Support		(Yes/No)	
Panel Absorber Surfaces Has Obvious Sign of Oxidation or De-colourisation		(Yes/No)	
Pipe Work, Heat Exchangers and Solar Hot Water Calorifier Are Well Insulated and With UV Protection Layer		(Yes/No)	
Hydraulic System Has Been Balanced		(Yes/No)	
All Valves Setting Are Appropriate		(Yes/No)	
All Electrical/Signal Connections of Sensors, Controllers and Data Acquisition Devices Are Properly Connected		(Yes/No)	
All Sensors Are Properly Installed		(Yes/No)	
All Sensors Have Been Calibrated		(Yes/No)	
All Sensors' Location Appropriate		(Yes/No)	
Automatic Air Vent Location Appropriate		(Yes/No)	
All Labels & Signages Are Provided		(Yes/No)	

Tested / Checked by : (Name of A/C Contractor's Representative)	Signature - ()	Post:	
		Tel. No.:	
		Date:	
Witnessed by: (Name(s) of *PBSE/PBSI)	Signature - ()	Post:	
		Tel. No.:	
		Date:	

4.23 Solar Water Heating System(Cont'd)

Location: _____

No: _____

Description	Designed Data	Test Results	Remarks
<u>Measurements</u>			
<u>Collector Panel Array</u>			
Solar Collector Type			
Solar Collector Grosse Area of Each Panel (mm x mm)			
Solar Collector Net Area (Absorber Area) of Each Panel (mm x mm)			
No. of Solar Collector Panels Connected In Serious Within A Bank			
No. of Solar Collector Panels Bank Connected In Parallel Within The Array			
Panel Tilted Angle (° to Horizontal)			
Panel Array Orientation			
Water Flow Rate of Solar Panel Array (l/s)			
Panel Array Entering Water Temperature (°C)			
Panel Array Leaving Water Temperature (°C)			
Panel Array Pressure Drop (kPa)			
Ambient Air Temperature (°C)			
Wind Speed (m/s)			
Solar Irradiation (W/m ²)			
Chemical Treatment		(Yes/No)	
- _____ (chemical) (ppm)			
- _____ (chemical) (ppm)			
- _____ (chemical) (ppm)			

Tested / Checked by : (Name of A/C Contractor's Representative)	Signature - ()	Post:	
		Tel. No.:	
		Date:	
Witnessed by: (Name(s) of *PBSE/PBSI)	Signature - ()	Post:	
		Tel. No.:	
		Date:	

4.23 Solar Water Heating System(Cont'd)

Location: _____

No: _____

Description	Designed Data	Test Results	Remarks
<u>System Controller</u>			
Circulation Pump Auto Start-Stop Setting (°C)			
- Temperature Different Between Solar Panel Output and Water Tank for Pump On			
- Temperature Different Between Solar Panel Output and Water Tank for Pump Off (°C)			
<u>Calorifier</u>			
Calorifier Storage Volume (m ³)			
Vent Type		(Vented/ Unvented)	
Calorifier Shell/lining Materials			
Pressure/Temperature Relief Valve Setting			
- Purging Temperature (°C)			
- Purging Pressure (kPa)			
Auxiliary Heater Type			
Auxiliary Heater Rating (kW)			
Over Temperature Thermostat Setting (°C)			
Calorifier Maximum Heat Transfer Capacity (kW)			
Pressure Drop of Calorifier Heating Loop (kPa)			
Insulation Type			
Insulation Thickness (mm)			
<u>Circulation Pumps</u>			
Voltage (V)			
Current (A)			
Power (W)			
Flow Rate (l/s)			
Pump Head (kPa)			

Tested / Checked by : (Name of A/C Contractor's Representative)	Signature - ()	Post:	
		Tel. No.:	
		Date:	
Witnessed by: (Name(s) of *PBSE/PBSI)	Signature - ()	Post:	
		Tel. No.:	
		Date:	

4.24 Checklist for Walkthrough Inspection

The walkthrough inspection is used to identify areas with a high potential for IAQ problems.

4.24.1 The following general requirements should be met before IAQ measurement:

- (a) Platforms are free of construction waste and debris;
- (b) Access doors to plantrooms are fitted and lockable;
- (c) All builder's works associated with IAQ systems completed and painted with dust preventing compound;
- (d) All ceiling works are completed;
- (e) All dust generating activities by other trades are completed and all areas thoroughly cleaned to prevent ingress of building dust and debris into the
- (f) Air intake screens and louvers are unobstructed and cleaned;
- (g) Fan and other equipment chambers are clean and free of construction debris;
- (h) Fans are checked for proper operation;
- (i) Floor gullies and drainage traps are clear and operational;
- (j) All condensate drains and trays are clear and water can be drained away satisfactorily;
- (k) Dampers are clean;
- (l) Ducting and other air passage ways are clean;
- (m) All outside air, return air, and spill air dampers are operative;
- (n) All volume control dampers are fitted and are at appropriate opening positions;
- (o) Ductwork systems are cleaned by purging of the supply air fan, or by robot duct cleaning recommended by the ductwork cleaning specialist;
- (p) All CAV and VAV terminals are installed, together with grilles and diffusers;
- (q) All filter media are installed;
- (r) Air conditioning systems and the building indoor area are purged to the standard acceptable by the Supervising Officer

4.24 Checklist for Walkthrough Inspection(Cont'd)**4.24.2 The following are general indicators of IAQ problems:**

- (a) Odour;
- (b) Dirty or unsanitary conditions (e.g. excessive dust);
- (c) Visible fungal growth or mouldy odour (often associated with problem of too much moisture);
- (d) Staining or discolouration of building materials;
- (e) Sanitary conditions in equipment such as drain pans and cooling towers;
- (f) Inadequate ventilation;
- (g) Inadequate exhaust air flow;
- (h) Blocked vents;
- (i) Uneven temperature;
- (j) Overcrowding;
- (k) Poorly-maintained filters;
- (l) Personal air cleaners (e.g. ozone generators);
- (m) Presence of hazardous substances; and
- (n) Unsanitary mechanical room, or trash or stored chemicals in mechanical room.

4.24 Checklist for Walkthrough Inspection(Cont'd)**4.24.3 Specifically, the following should be addressed:**

4.24.3.1 Thermal comfort

- (a) Check for any evidence of high or low temperature. Are these due to occupant interference, such as installation of new equipment?
- (b) Check for evidence of thermal gradients; the floor-to-ceiling differential should not exceed 3°C.
- (c) Check for any obstruction of air circulation, such as partitions, taped diffusers, or blocked by paper, books, or cabinets.
- (d) Ensure that thermostats are functioning, calibrated, correctly located, and not obstructed or enclosed.
- (e) Is there system intervention, such as blockage of the ventilation grilles?

4.24.3.2 Potential sources of contaminants

- (a) Enquire about any recent change in the physical set-up and use of the space (e.g. open office space converted to closed offices, transformation of office space into a waiting room, computer room etc.).
- (b) Inspect the loading dock and car parks connected with the premises:
 - Are they properly ventilated?
 - Are stairways, elevator shafts, and ducts acting as pathways for automobile exhaust and diesel fumes?
 - Are carbon monoxide sensors (for ventilation control) and alarms installed in the garage calibrated and operating properly?
- (c) Are stoves and other sources fitted with exhaust system?
- (d) Is the building less than a year old, or has any area been renovated, redecorated or newly furnished within the past month?
- (e) Are suitable cleaning products being employed? Is time of use optimum, so as to reduce exposure of occupants?
- (f) Do any activities involve the use of large amounts of chemicals, especially highly volatile solvents? Is solvent odour present? Are soaked materials and solvents being disposed of properly?

4.24 Checklist for Walkthrough Inspection(Cont'd)

- (g) Have pesticides been improperly applied?
- (h) Is the trash properly disposed of daily?
- (i) Is extra ventilation or a separate ventilation system being used where there are localised sources? Is the ventilation system recirculating volatile organic compounds from a source throughout the building?
- (j) Any mouldy, damp odour, evidence of a previous flood or water leak?
- (k) Records should be examined for evidence of recent renovation, painting, installation of plywood or particleboard, replacement of carpets, and installation of new furniture.
- (l) Are there dirt marks or white dust on diffusers, indicating particulates entering from the ventilation system?
- (m) Is smoking only restricted to designated areas with independent ventilation system?
- (n) Are the carpets cleaned regularly?

4.24.3.3 Air-conditioning and Mechanical Ventilation (ACMV) system

- (a) Is the amount of fresh air provided to the premises in line with the "ANSI/ASHRAE Standard 62.1-2016: Ventilation for Acceptable Indoor Air Quality"?
- (b) Where is the fresh air intake duct located? Is it blocked up? Is it near the cooling tower? Is it at street level or near a car park (Air intakes located below third-floor level can conduct fumes from vehicular traffic, parking garages)? Are heavy industries located nearby? Is there any construction work going on nearby?
- (c) Are the outside air controls and dampers functioning properly?
- (d) Is the minimum outside air damper opening set at approximately 15%?
- (e) Are all air distribution dampers functioning properly and cleared of obstruction?
- (f) Are filters installed and maintained properly (e.g. no bypassing, not overloading with dust)?
- (g) Is the filtering system designed for primary filters, rated between 10% and 30% dust-spot efficiency, and for secondary filters, rated between 40% and 85% dust-spot efficiency?

4.24 Checklist for Walkthrough Inspection(Cont'd)

- (h) Are the drain pans clean, properly drained, and without visible mould growth?
- (i) Are the fan motors and belts working properly?
- (j) Are diffusers and exhaust outlets close together, thereby causing short-circuiting?
- (k) Is the air-conditioning system turned off any time during the day?
- (l) Is there a regular schedule for cleaning and maintenance of the ACMV system in the building?
- (m) Are all the components of the ACMV system regularly inspected for leaks, breaches, etc.?
- (n) Do the cooling towers treated according to the "Code of Practice for Prevention of Legionnaires' Disease" published by Prevention of Legionnaires' Disease Committee, Hong Kong?
- (o) Are the mechanical rooms clean and free of contaminant (e.g. refuse, chemicals)?
- (p) Are the exhaust fans operating properly?
- (q) Are all air distribution path unobstructed?

4.24.3.4 Other Conditions not mentioned above but considered as relevant to IAQ

Qualified Examiner: _____
 (Name in Block Letter) (Signature) (Date)

(see the General Specification D.11)

4.27 Testing and Commissioning Records of IAQ Measurement by Passive Sampler

Site/Project: _____ Parameter: _____

Name and model of passive sampler: _____

Name of Laboratory: _____

Sampling position	Average	Date/time of the sampling	Identification and Batch no. of sampler	Remark

Total average: _____

Outdoor air:

Identification and Batch no. of sampler:	
Date/time of the sampling:	
Average value:	

Sample taking technician: _____

Qualified Examiner: _____
 (Name) (Signature) (Date)

(see the General Specification D.11)

The Original of Laboratory Report should be attached to the copy submitted to the PBSE.

4.28 Testing and Commissioning Records of IAQ Measurement of Air Borne Bacteria

Site/Project: _____

Sampling position 1: _____

Sample ID	First Plate count	Second Plate count	Average Plate count	Sampling Date/Time	Air volume	Colony (cfu/m ³)
Average of this position:						

(Prepare the following data entry table for each Sampling position: -)

Sampling position _____

Sample ID	First Plate count	Second Plate count	Average Plate count	Sampling Date/Time	Air volume	Colony (cfu/m ³)
Average of this position:						

Average of Colony Count of all sample positions: _____ cfu/m³Colony Count of Outdoor Air: _____ cfu/m³

Impactor model and serial no: _____ Last calibration date: _____

Agar type: _____ Agar Batch no.: _____

Name of technician /Supplier preparing the Agar: _____

Date of agar prepared: _____

Sample taking technician: _____

Incubation technician: _____

Qualified Examiner: _____

(Name)

(Signature)

(Date)

(see the General Specification D.11)

Flow Charts

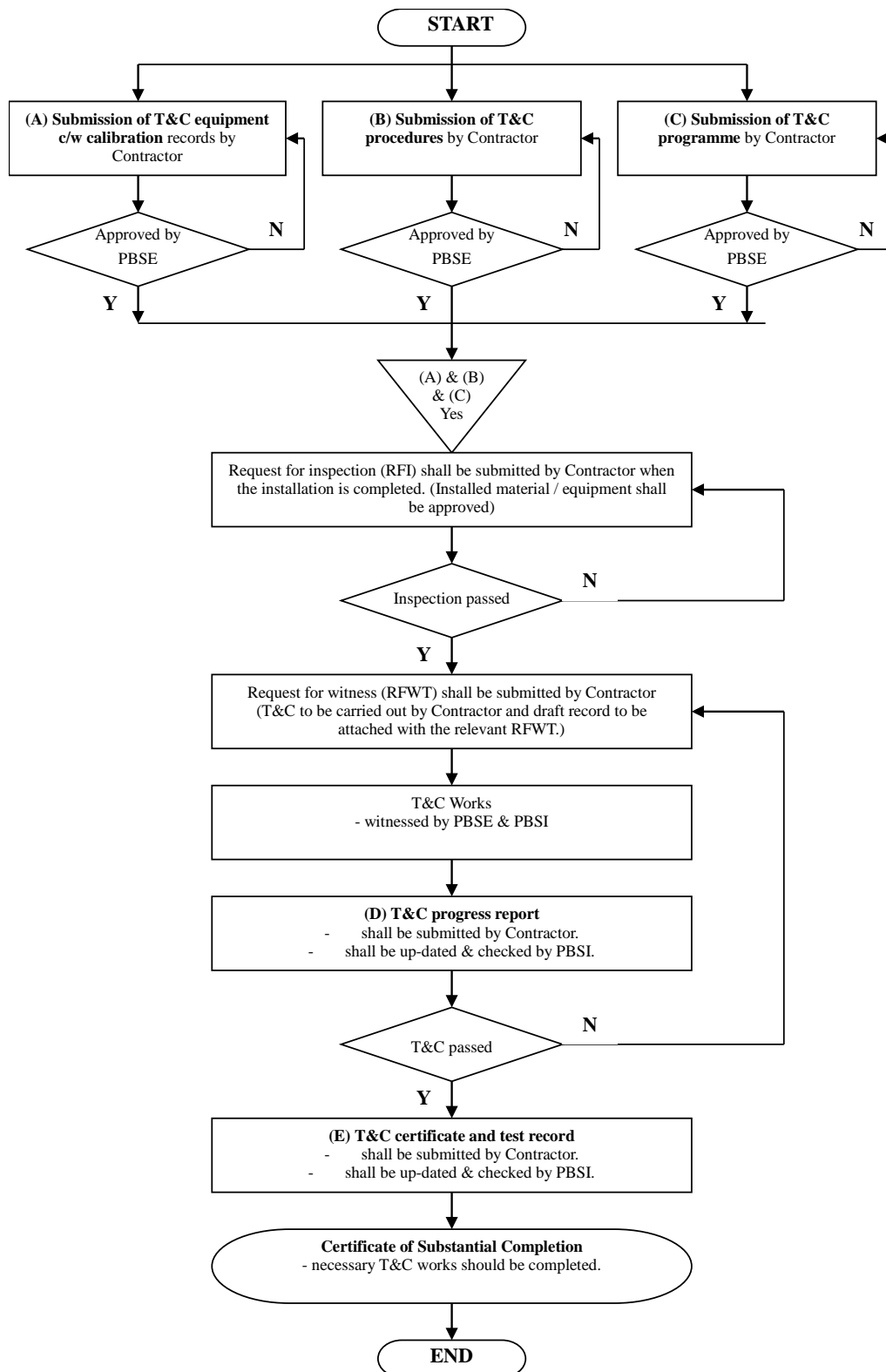

Fig.1 Flow Chart for T&C Procedure

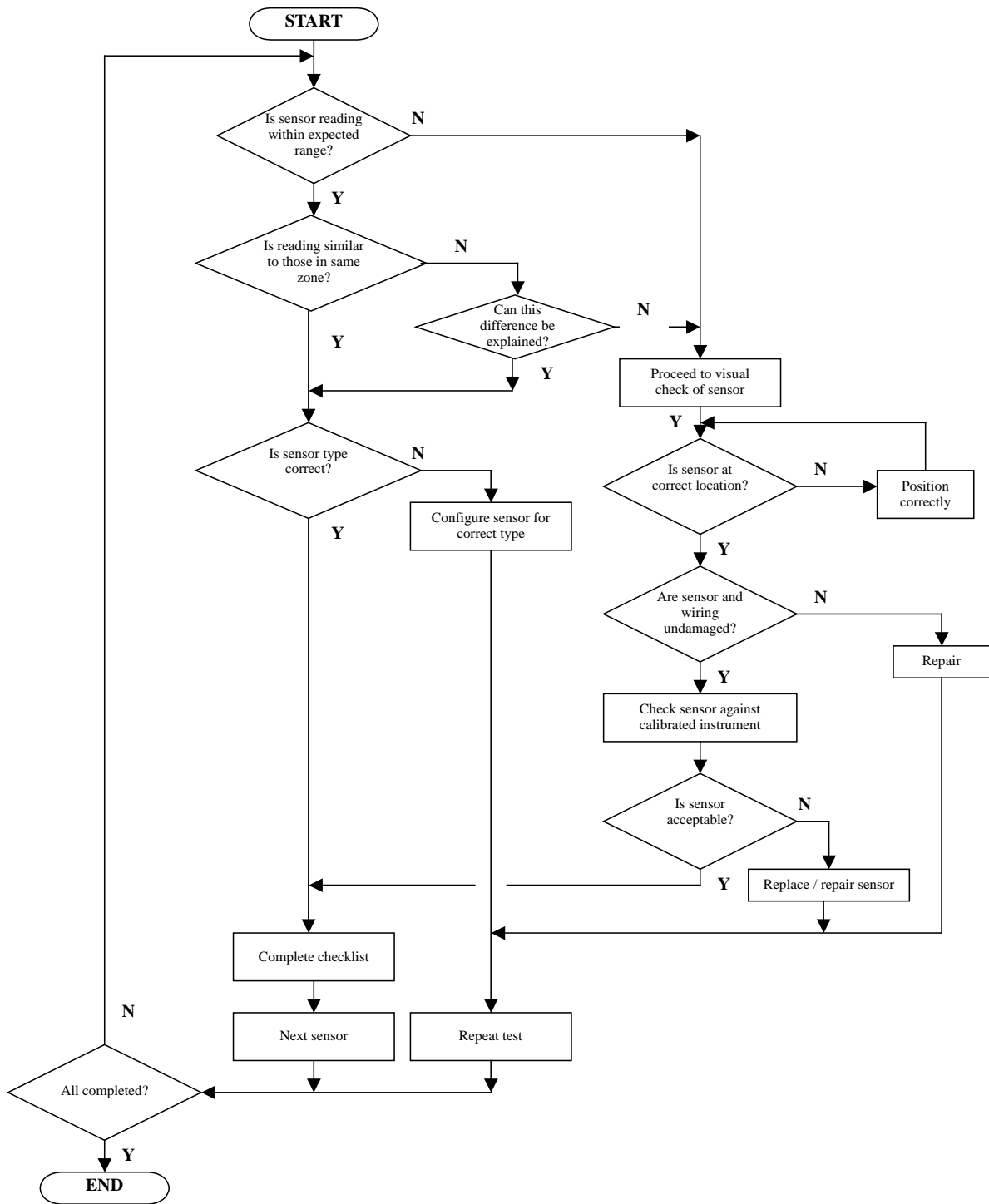

Fig.2 Sensor Checking Flow Chart

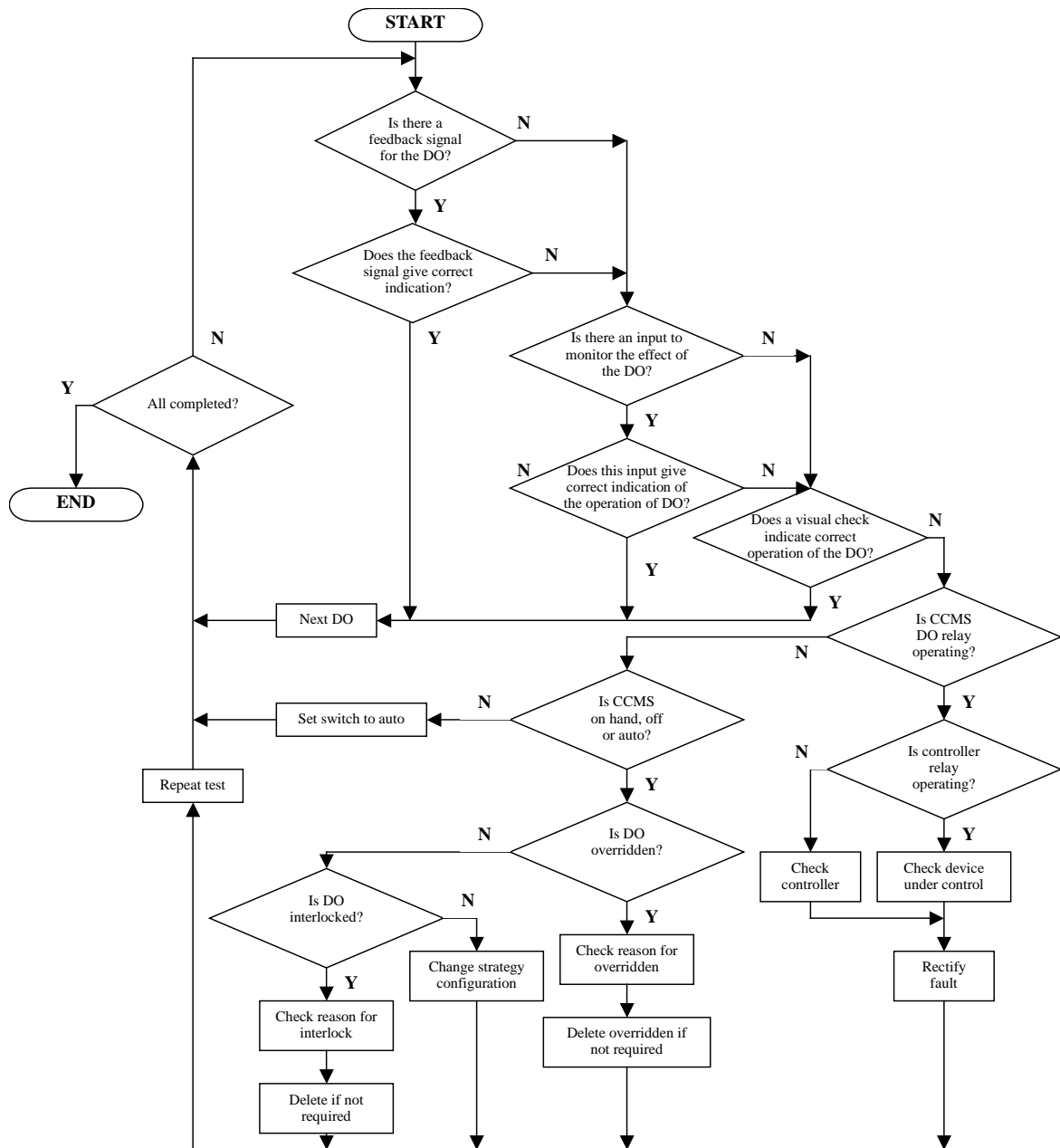

Fig.3 Digital Output (DO) Checking Flow Chart

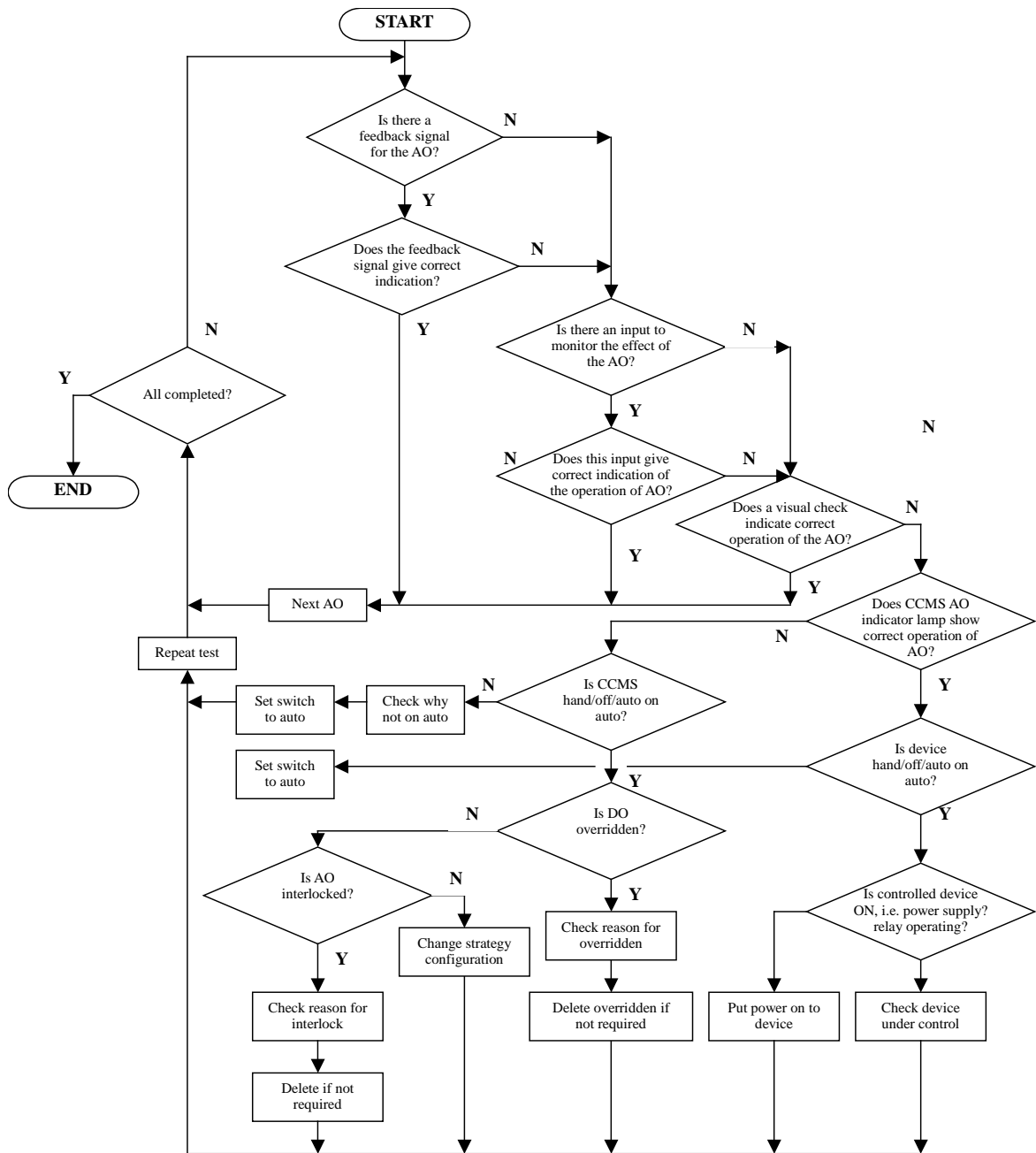

Fig. 4 Analogue Output (AO) Checking Flow Chart

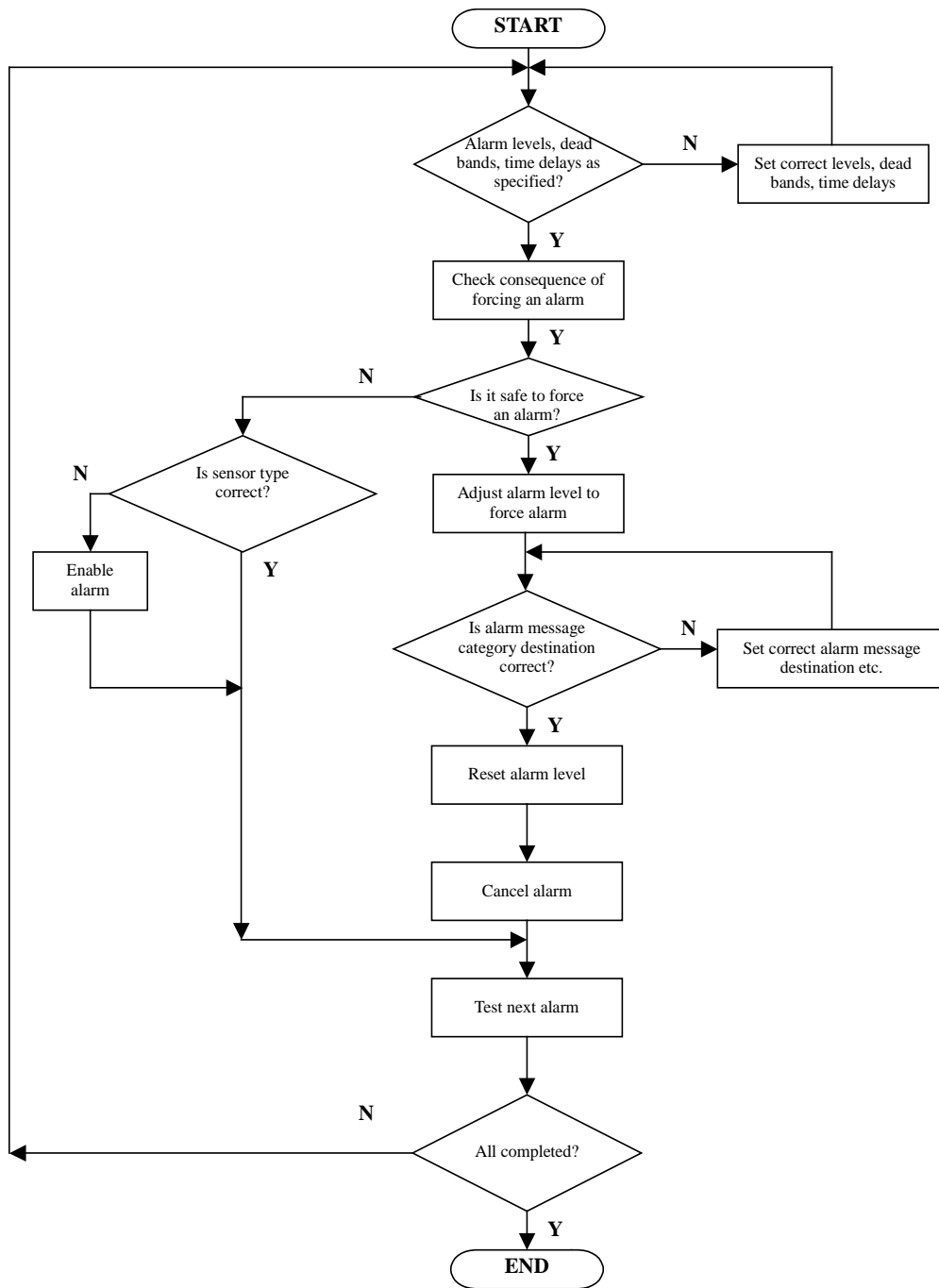

Fig. 5 Alarm Checking Flow Chart

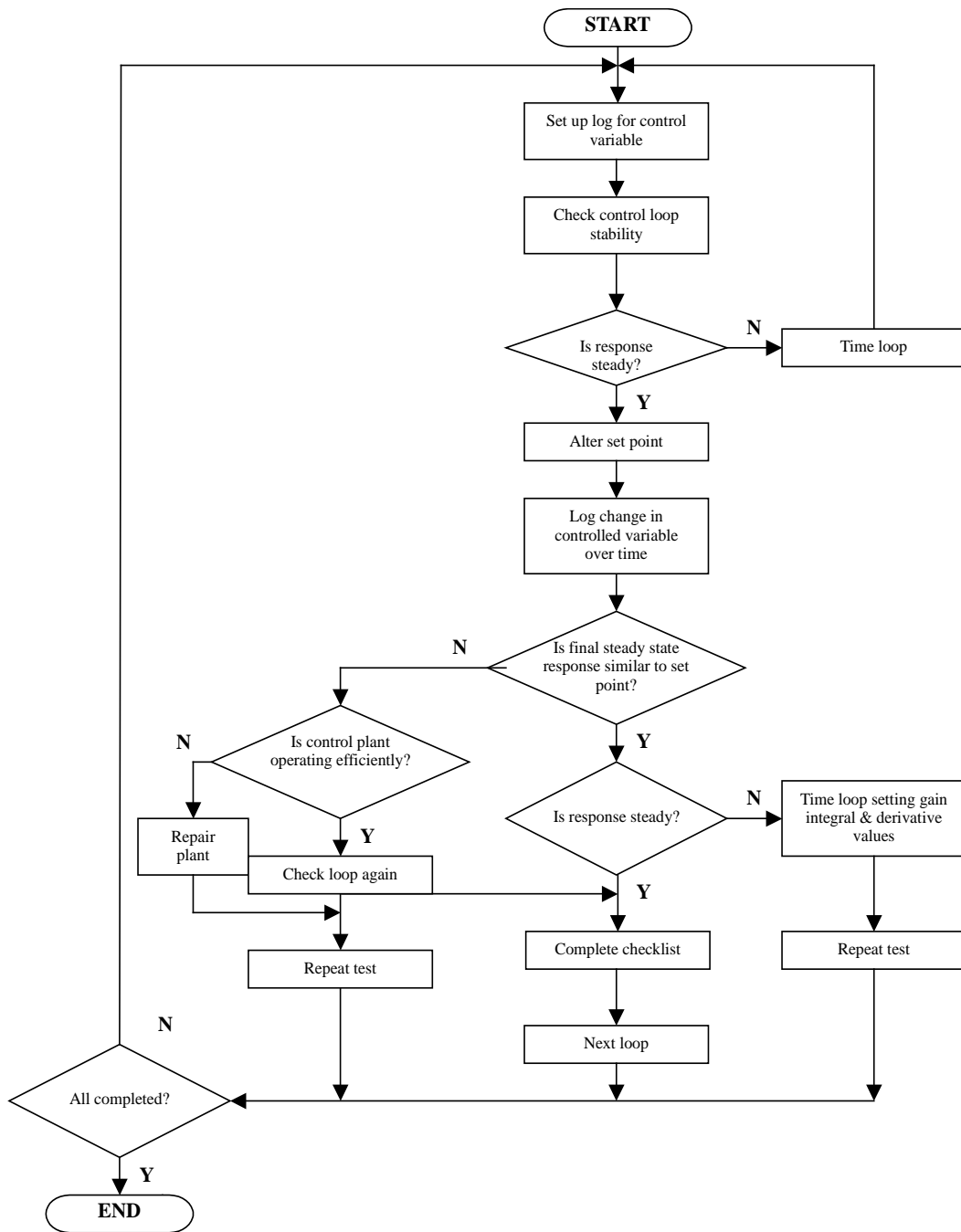

Fig. 6 Control Loop Checking Flow Chart

Reference For Testing and Commissioning Procedures

1. Measurement Principles of Real-time IAQ Monitors

IAQ Parameter	Measurement Principle	Accuracy	Example of Calibration Method
Temp.	Thermistor	$\pm 0.6^{\circ}\text{C}$	Platinum PRT's calibrated against NIST primary cells
RH	Thin-film capacitive	$\pm 5\%$	Environmental chamber with extreme accurate RH control traceable to international or national standards
Air movement	Hot-wire anemometer	The larger of $\pm 5\%$ or $\pm 0.1\text{m/s}$	Flow tubes as primary standards with their flowrate calibrations directly traceable to length and time standards
CO ₂	Non-dispersive infrared	The larger of $\pm 5\%$ or $\pm 50\text{ ppm}$	Bottled Standard Reference gas traceable to international or national standards
CO	Electrochemical	The larger of $\pm 5\%$ or $\pm 2\text{ ppm}$	Bottled Standard Reference gas traceable to international or national standards
NO ₂	Chemiluminescence	$\pm 1\%$	Bottled Standard Reference gas traceable to international or national standards
TVOC	Photo-ionisation sensor with super bright 10.6eV calibrated against Isobutylene	The larger of $\pm 10\%$ or $\pm 20\text{ ppb}$	Bottled Standard Reference Isobutylene gas traceable to international or national standards
HCHO	Electrochemical or Electrolysis		Environmental chamber with known HCHO concentration traceable to international or national standards
Rn	Electrostatic collection of alpha-emitters with spectral analysis looks at the 6 MeV alpha particles from the Polonium-218 decay.		Environmental chamber with known Rn concentration traceable to international or national standards
RSP	90 degree light scattering laser photometer fitted with filter for measurement of PM10 particles	The larger of $\pm 0.1\%$ or $\pm 1\ \mu\text{m}/\text{m}^3$	Arizona Road Dust (ARD) compared with NIOSH Method 0600 for respirable dust
O ₃	Heated metal oxide semiconductor / Electrochemical	$\pm 10\%$	Comparison with an NIST traceable UV analyser

The calibration of all monitors shall be traceable to international and/or national standards (e.g. National Institute of Standards and Technology standards).

2. Example of Air Flow Sheet

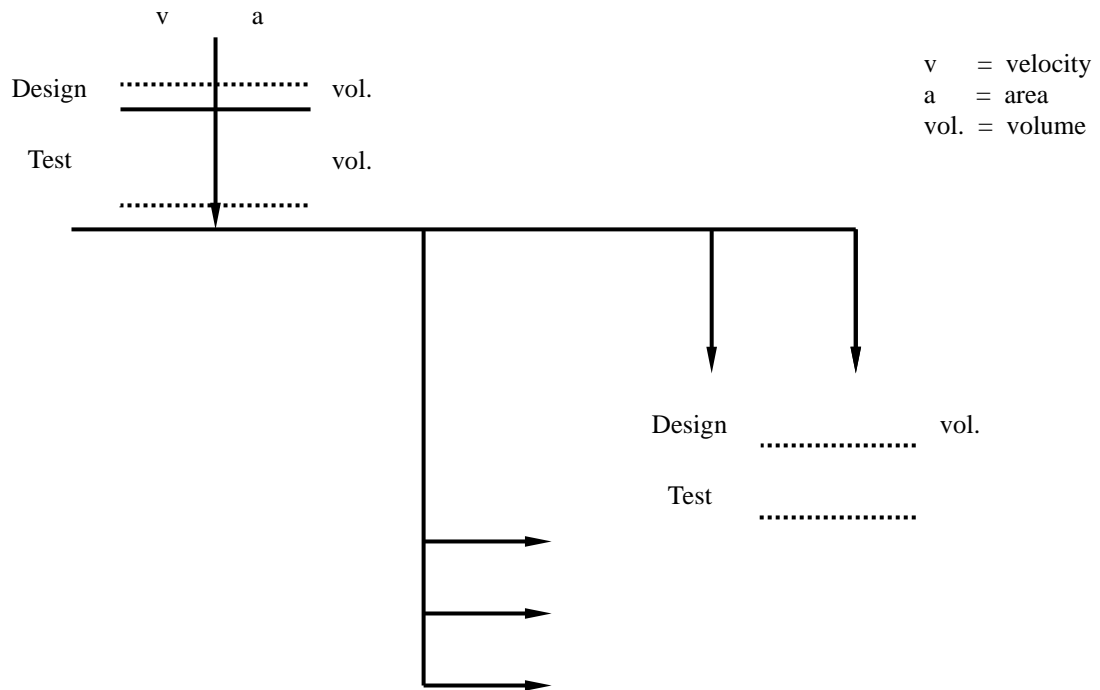

3. Illustration of Balancing Procedures

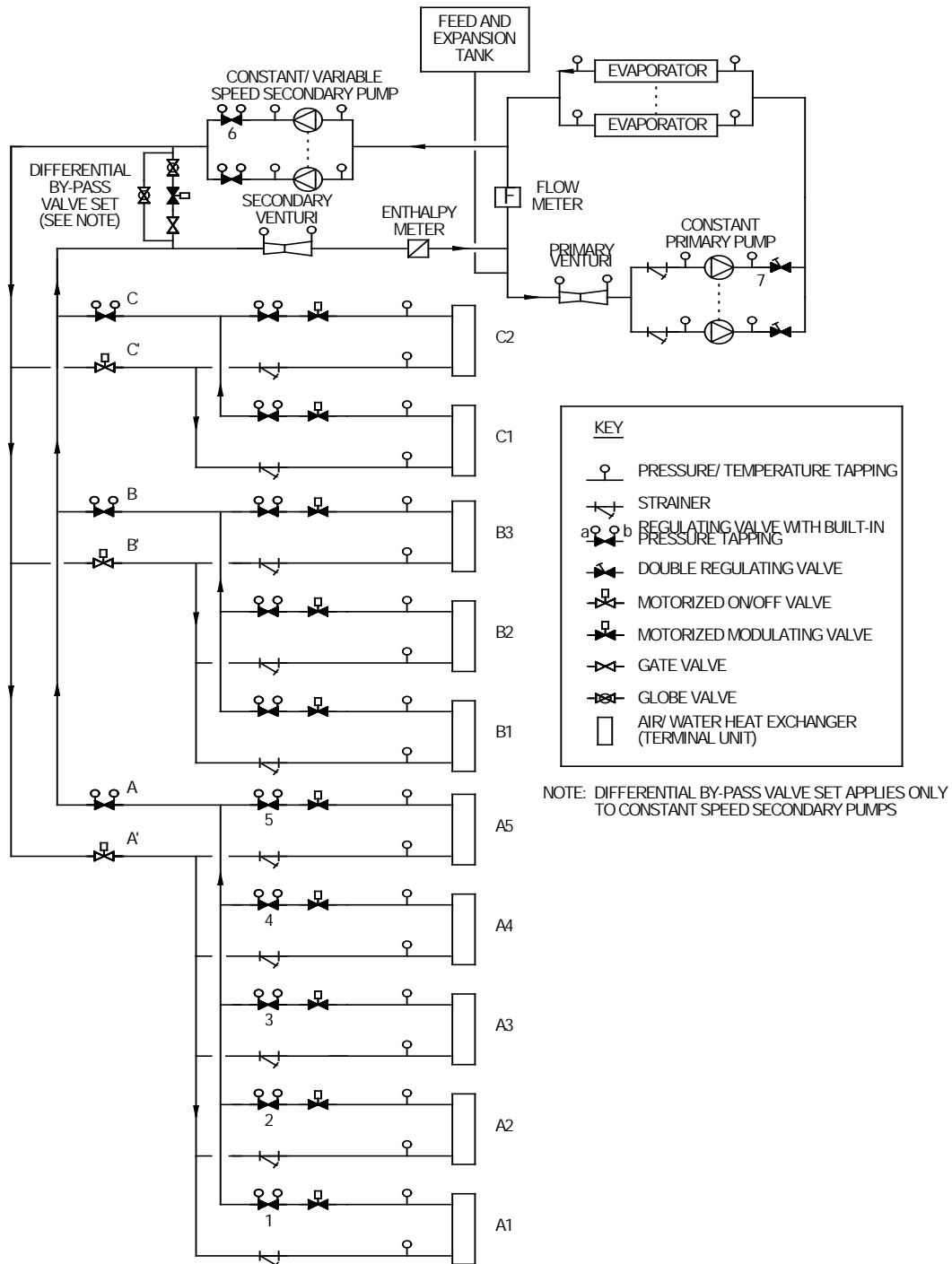

Fig. V - Example of Water Distribution System

3.1 General Description of the Water Distribution System

- (a) chilled water system as shown in Fig. V will be used to illustrate the balancing procedures. The procedures for chilled water circuitry are equally applicable to heating and condensing water circuitry;
- (b) the performance of terminal plant in chilled water systems is considerably more sensitive to any deviations from the design water flow rate. Hence, the T&C procedure for chilled water systems requires more exacting tolerances than heating system when balancing;
- (c) the flow to each branch circuit is controlled by a two-way motorised on/off control valve;
- (d) the return line from each terminal unit is fitted with a motorised modulating valve. Downstream in series is a regulating valve which has built-in pressure tapings. This valve is used for both the water flow regulations and measurement. This valve is locked in position after the balancing procedure is completed.

3.2 Initial Check of System Water Flow Rates

- (a) check the pressure drop across the associated flow regulating valve of each terminal unit and branch by connecting a manometer between points a and b of the regulating valve with built-in pressure tapping. (Refer to Fig. V);
- (b) compute the square root of the ratio of the actual-to-design pressure drop for each branch and terminal;
- (c) determine which is the least favoured (index) branch and which is the most favoured branch. The branch with the highest ratio is taken as the most favoured branch, whereas the branch with the smallest ratio is the least favoured branch, i.e. the index branch.

3.3 Balancing of Terminals

- (a) start by balancing the most favoured branch first;
- (b) balance the water flow rate of each terminal unit to the water flow rate of the index terminal unit in that branch;
- (c) balance the water flow rate of each branch independently. (The main branch valves A, A', B, B', C, C' regulating valves with built in pressure tappings and motorised modulating valves of terminal units in Fig. V are all fully open at this stage);
- (d) assume branch A-A' has the highest ratio (i.e. the most favoured) and unit A1 (remote in hydraulic terms relative to the circulating pump) is the least favoured. If it is not, connect 1 manometer across valve No. 1 and a second manometer across the regulating valve at the least favoured terminal unit; (take regulative valve No. 2 in this case for illustration)

- (e) regulate valve No. 2 until the percentage of design water flow rate across the 2 valves is equal (or within the designer's tolerances);
- (f) leave the first manometer connected across valve No. 1 (a and b) while the rest of the branch A-A' is balanced;
- (g) connect the second manometer across valve No. 3. Regulate valve No. 3 until the percentage of design water flow rate is the same (or within the designer's tolerances) as valve No. 1;
- (h) repeat this T&C Procedure for all valves on branch A-A';
- (i) remove both manometers and start on the next most favoured branch;
- (j) repeat until the water flow rates of all terminal units on all branches are balanced within each branch.

3.4 Balancing of Complete Branches

- (a) for this stage, the branch regulation valves (A, B and C) will be the measuring stations;
- (b) check the percentage of design water flow rate across each branch regulating valve and determine which is the index branch (say branch B-B');
- (c) set the first manometer across valve No. B' and the second manometer across valve A' until the percentage of design water flow rates across the valves A and B are equal (or within the designer's tolerances for branch balance);
- (d) leave the first manometer connected across valve B. Repeat this T&C Procedure for all branches (in this example for branch C-C') working back from the most remote branch to the branch nearest the pump. (Where, at the start of branch balancing, if the most remote branch is not the index or least favoured branch, it should be made so, in the manner described for terminal balance.)

3.5 Balancing of Secondary Pumps

- (a) set the pump speed at designed maximum flow conditions for variable speed pump;
- (b) measure the water flow by connecting a manometer across the regulating valve No.6. Adjust the regulating valve until the pressure drop across the valve equals the design pressure drop;
- (c) counter check the flow by using the secondary venturi or other flow meters in the circuit;
- (d) repeat the procedures for all secondary pumps.

3.6 Balancing of Primary Pumps

- measure the water flow by connecting a manometer across the primary venturi. Adjust the regulating valve or globe valve No.7 until the pressure drop across the venturi equals the design pressure drop;
- counter check the flow by referring to other flow meters in the circuit;
- repeat the procedures for all primary pumps;
- re-scan all measuring stations for record and monitoring purposes including the pump differential pressures.

4. Principle of Proportional Air Balancing

This is demonstrated in Table V1, X is the main flow, and Y and Z the branch-offs. The essence of the method is to regulate flow by targeting on the ratio between branch-offs Y and Z. Balancing is done by taking Y as the reference point.

	X		Y	Z	
	m ³ /s	% of design	m ³ /s	m ³ /s	% of Y
Design flow	3		1	2	200%
Measurement and Regulation					
Initial condition before balancing with Dampers at Y and X fully open	3.43		1.58	1.85	117%
Carry out Balancing by <u>Regulating Damper at Y</u> to bring the flows at Y and Z to the same proportion as at design (i.e. Z at 200% of Y)	3.3	110%	1.1	2.2	200%
Finally <u>Regulate Damper at X</u> to bring all flows to design condition	3		1	2	
Note: Device at X may be a fan speed controller (e.g. variable speed drive) instead of damper					

Table V1- Principle of Proportional Air Balancing

4.1 Preparation

The proportional balancing method, including preparatory work, is illustrated below in the following typical low velocity supply air system diagram (Fig. V1).

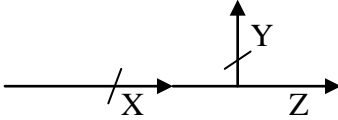
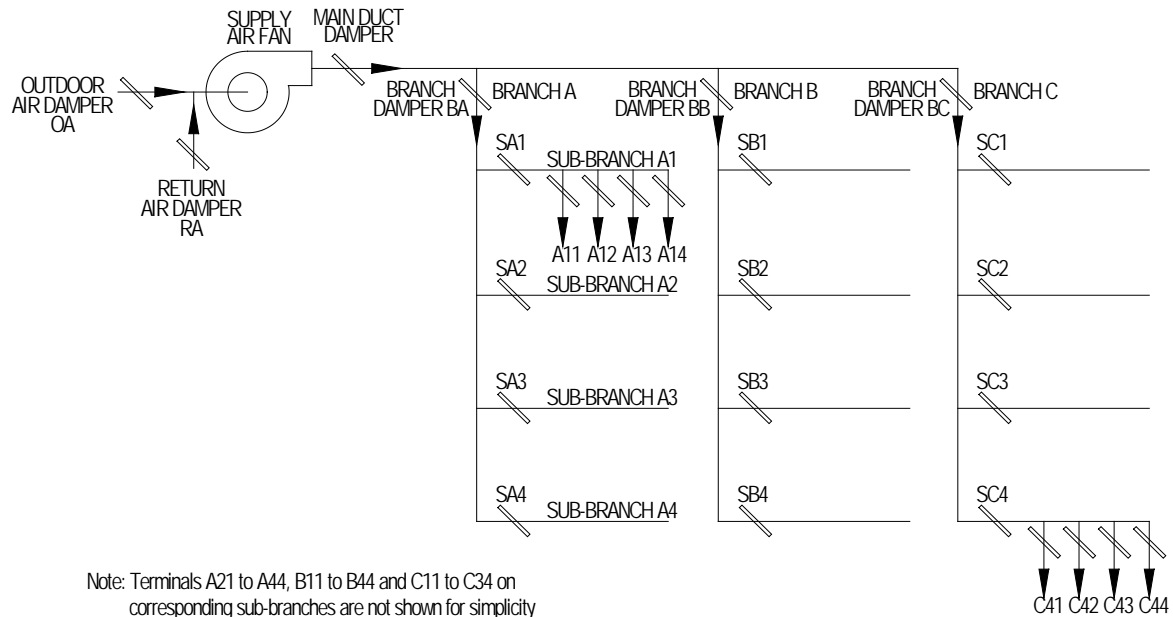

Fig V1 - A Typical Low Velocity Supply Air Diagram

- (a) check that dampers on all terminal grilles/diffusers A11, A12, A13, A14, A21 to 24, A31 to A34, A41 to A44, B11 to B44 and C11 to C44 are fully open, adjustable louvers without deflection, and adjustable cones fully open;
- (b) set all Branch dampers BA, BB, BC, and Sub-branch dampers SA1 to SA4, SB1 to SB4 and SC1 to SC4 fully open;
- (c) set OA and RA to opposite extreme positions, either OA fully open with RA fully closed or vice versa. Set main duct damper (M) if available to fully open;
- (d) carefully monitoring the running current, start the fan. It will deliver a higher than design airflow since all the dampers are open. Avoid overloading the fan motor. If the current appears to be excessive, stop the fan. Simulate an increase in system losses before restart. This can be done by slightly throttling OA (or RA, depending on which has been chosen to be fully open) or M;
- (e) measure the air flow rates of all air Terminals. The measurement shall be carried out preferably using the same measuring device (for Terminals in the same system). This is to avoid irregularity between different measuring devices;

- (f) for the purpose of having truly comparable readings, these measurements shall be made in one quick continuous operation to avoid change of operating conditions and site environment over time;

Measured flow of air Terminals																	Total			
Sub-Branch A1					Sub-Branch A2					Sub-Branch A3					Sub-Branch A4				Branch	
11	12	13	14	A1	21	22	23	24	A2	31	32	33	34	A3	42	42	43	44	A4	A
Measured flow																				
Ratio of measurement to design in %																				
Sub-Branch B1					Sub-Branch B2					Sub-Branch B3					Sub-Branch B4				Branch	
11	12	13	14	B1	21	22	23	24	B2	31	32	33	34	B3	42	42	43	44	B4	B
Measured flow																				
Ratio of measurement to design in %																				
Sub-Branch C1					Sub-Branch C2					Sub-Branch C3					Sub-Branch C4				Branch	
11	12	13	14	C1	21	22	23	24	C2	31	32	33	34	C3	42	42	43	44	C4	C
Measured flow																				
Ratio of measurement to design in %																				
System flow																				
% of design flow																				

Table V2 – Measured Flow of Air Terminals

- (g) prepare a table (similar to Table V2) readily indicating the initial measured flows of each Terminal, Sub-branch, Branch and Main. Express the measurements as percentages of design values;
- (h) study the general pattern of these initial readings. Check for any abnormalities:
- (i) flow lower than 100%,
 - (ii) large differences between branches of similar run and size,
 - (iii) large differences between adjacent air terminals etc.
- abnormalities may indicate excessive leakage, improper closing of dampers and other problems. Refer unresolved problems to the PBSE if necessary;
- (i) for Branches, the preferred sequence is in descending order of measurement to design ratio, i.e. start balancing with the Branch having the highest measurement to design ratio. Usually, the Branch nearest (duct run distance) to the fan would have the highest ratio;

- (j) for Sub-branches, the preferred sequence is again in descending order of measurement to design ratio. Usually, the Sub-branch nearest (duct run distance) to the fan would have the highest ratio;
- (k) for Sub-branches, the preferred sequence is again in descending order of measurement to design ratio. Usually, the Sub-branch nearest (duct run distance) to the fan would have the highest ratio;
- (l) should there be inadequate airflow in a Sub-branch for measurement taking, the dampers in other Sub-branches may be slightly closed so as provide more flow to the Sub-branch in question.

4.2 Regulating of Air Terminals

- (a) determine the Terminals on each Sub-branch with the lowest measurement to design ratio. This Terminal (T) is to be used as the Index Terminal (IT) during balancing of the corresponding Sub-branch. It is usually the farthest Terminal downstream;
- (b) for each Sub-branch, prepare a table listing the ratio of measurement to design flow rates of all Terminals, such as the one shown in Table V3;

Sub-branch <u>SA1</u>	Index Terminal IT	Terminal T		
	A14	A11	A12	A13
Ratio of measurement to design (%)				

Table V3 – Ratio of Measurement to Design Flow Rates of Terminals

- (c) assuming that Sub-branch SA1 has the highest measurement to design flow ratio, it shall be the one to be balanced first (according to (k) in section 4.1 above);
- (d) assuming that Terminal A14, the one farthest away from the fan, has the lowest measurement to design flow ratio, it is taken as the IT;
- (e) should A14 turns out not to be the Terminal with minimum measurement to design ratio, gradually close A14's damper until it has the lowest ratio. Take A14 as the IT;
- (f) proceed with the reiteration steps according to the flow chart in Fig V2. Start off with a Terminal adjacent to IT, in the direction of duct path towards the fan;

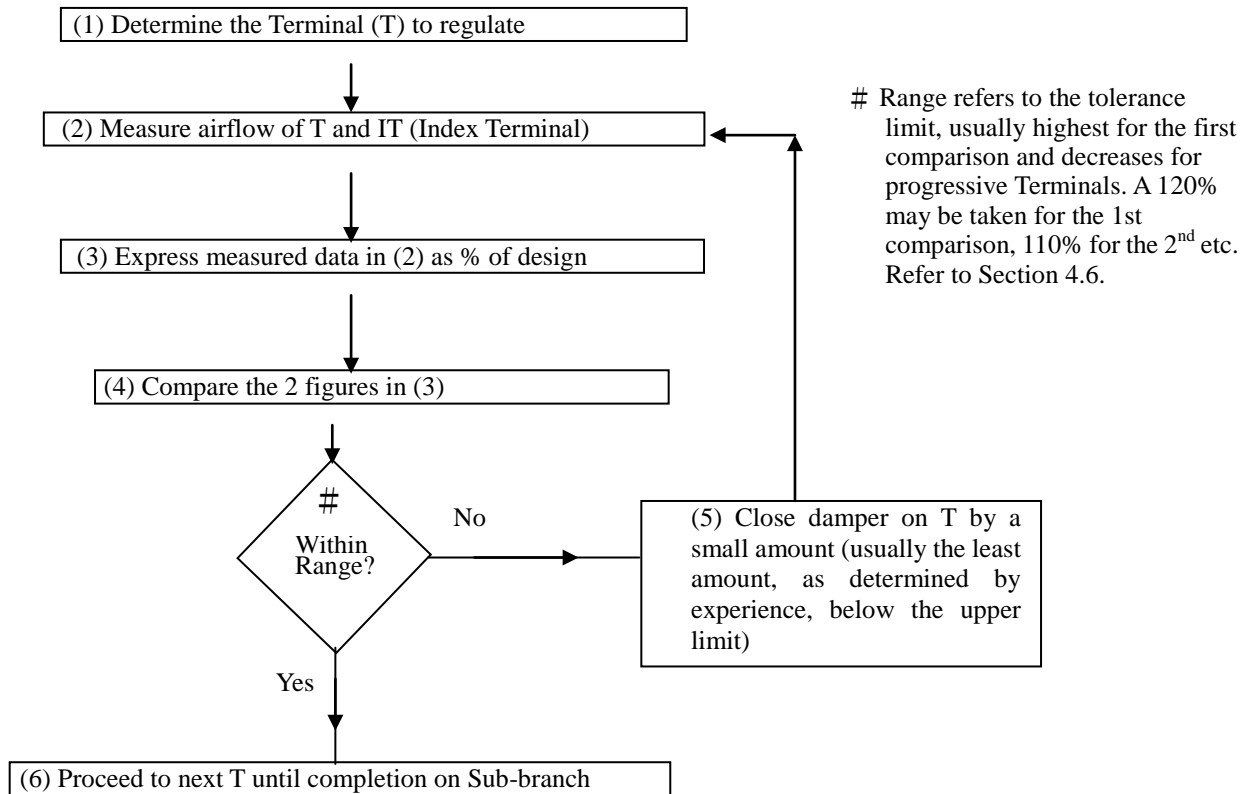

Fig. V2 - Flow chart for Regulation of Terminals

- (g) it is impractical to have identical measured flows from 2 identical Terminals with same design flow. Tolerance in measurement is allowed in accordance with section 4.6 below;
- (h) it is preferable to use the same set of measuring device to avoid irregularities. For the purpose of having truly comparable readings, these measurements shall be made in one continuous operation to avoid change of operating conditions and site environment over time;
- (i) it is preferable to use the same set of measuring device to avoid irregularities. For the purpose of having truly comparable readings, these measurements shall be made in one continuous operation to avoid change of operating conditions and site environment over time;
- (j) lock (or mark, if locking not practical) the positions of dampers of regulated Terminals;
- (k) after setting of dampers of all Terminals in the Sub-branch, carry out the same for all other Sub-branches;
- (l) after setting of dampers of Terminals in all Sub-branches, carry out the same balancing work for all other Branches;

- (m) throughout the process, maintain the balanced Sub-branches at between 70% and 130% of design flow rate. (This can be done by adjusting OA/RA or M. However if such an adjustment is made whilst regulating the Terminals in a certain Sub-branch, measurements have to repeat for all Terminals of the Sub-branch in question.);
- (n) throughout the process, make sure that dampers in all Sub-branches and Branches are not disturbed;
- (o) it should be noted that the Terminals are still not operating at their design flow rates at this stage. However, all Terminals are handling the same ratio of flow to their corresponding design values;
- (p) only after completing the regulating works for all Terminals can the balancing of Sub-branch is proceeded.

4.3 Air balancing of Sub-Branches

- (a) the method is similar to section 4.2 above, except this time it is the dampers in Sub-branches that are to be regulated. Start off by measuring the flow in each Sub-branch;

Measured flow of Sub-branches				Total of Branch/System
A1	A2	A3	A4	Branch A
Ratio of measurement to design in %				
B1	B2	B3	B4	Branch B
Ratio of measurement to design in %				
C1	C2	C3	C4	Branch C
Ratio of measurement to design in %				
System flow				
% of design				

Table V4A – Measured Flows of Sub-Branches

- (b) prepare a table (similar to Table V4A) readily indicating the measured flows of each Sub-branch, Branch and Main. Express the measurements as percentages of design values;
- (c) should there be inadequate test holes for measurement in Sub-branch, measurement can be taken at the Index Terminal. The Index Terminal's measurement to design ratio in percentage can be used to represent the percentage of measurement to design flow of the Sub-branch;

- (d) assuming that Branch A has the highest ratio, it shall be the one to be balanced first (according to (a) in section 4.1 above);
- (e) determine the Sub-branch on each Branch with the lowest measurement to design flow ratio. This Sub-branch (SB) is to be used as the Index Sub-branch (IS) during balancing. Assuming SA4 has the lowest measurement to design ratio, it is taken as the IS;
- (f) for each Branch, prepare a table listing the ratio of measured flow rates of all Sub-branch to their corresponding design flow rates, such as the one shown on Table V4B;

Branch <u>A</u>	Index Sub-branch IS	Sub-branch SB		
	SA4	SA1	SA2	SA3
Ratio of measurement to design (%)				

Table V4B – Ratio of Measured Flow Rate of Sub-Branche

- (g) proceed with the reiterative steps of balancing according to the flowchart in Fig. V3 Start off with an adjacent Sub-branch.

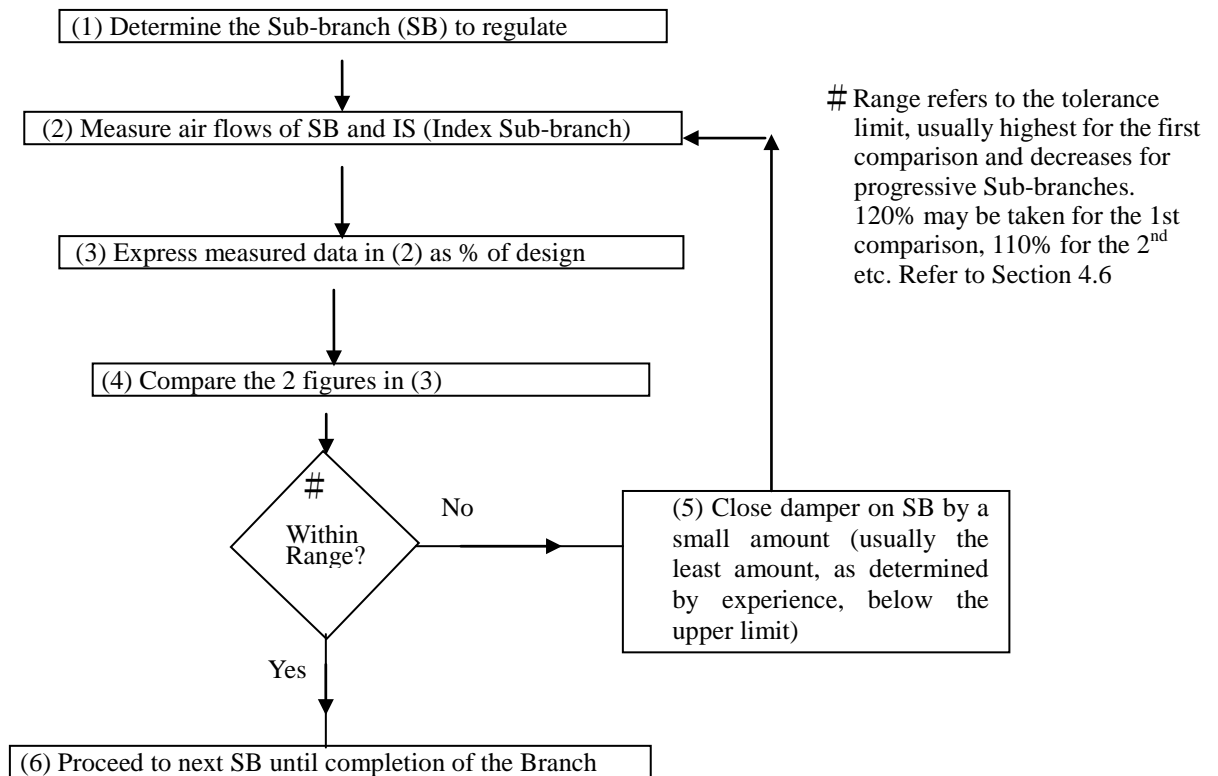

Fig. V3 - Flow chart for Air-balancing of Sub-Branche

- (h) it is preferable to use the same set of measuring device to avoid irregularities. For purpose of having truly comparable readings, these measurements shall be made in one continuous operation to avoid change of operating conditions and site environment over time;
- (i) tolerance in measurement is allowed in accordance with section 4.6 below;
- (j) lock the positions of dampers of balanced Sub-branches;
- (k) after setting of Dampers on all Sub-branches in the same Branch, carry out the same for all other Branches;
- (l) throughout the process, maintain the balanced Sub-branches at between 70% and 130% of design flow rate;
- (m) throughout the process, make sure that dampers in all Branches are not disturbed;
- (n) it should be noted that the Sub-branches are still not operating at their design flow rates at this stage. However, all are handling the same ratio of flow to their corresponding design values;
- (o) only after completing the air balancing works for all Sub-branches can the balancing of Branch is proceeded.

4.4 Air balancing of Branch and regulation of total system flow

- (a) branch Dampers BA, BB & BC are to be regulated. The method is same as for balancing for Sub-branches;
- (b) determine the Branch with the lowest measurement to design flow ratio. This Branch is to be used as the Index Branch (IB) during balancing. Assuming BC has the lowest measurement to design ratio, it is taken as the IB;
- (c) carry out similar exercise as described in (g) in section 4.3 above, and take note of the pre-cautions and remarks in (h) to (o).

4.5 Regulation of total system flow

- (a) after completing air balancing of all Branches, it is time to regulate the total system flow;
- (b) measure the total airflow in the main duct. Where it is not practical to do so, Branch flow rates can be added together to establish the total flow;
- (c) wherever practical, filters if any in the system should be cleaned;

- (d) compare the measured figure with the corresponding design value. Regulate the fan output until the measured value is within the tolerance of the total flow;
- (e) where the system contains automatically operated dampers for varying proportions of fresh/exhaust/recirculation or face and by-pass dampers, measurement of the total air flow and regulations of the fan output should be conducted with these dampers in the full fresh air, full exhaust or full face positions, in accordance to the different design modes of operation. Measurement of flow with damper positions at the other design extremes should be taken. These measured results should be compared to corresponding design values;
- (f) wherever a system is directly connected with another system, e.g. supply connected with an extract via a recirculation duct with fixed or variable mixing dampers, first proportionally balance the duct run of both systems independently. Then regulate the total airflow in both systems with the dampers set as described in (e). Care should be exercised to mark or register on the damper linkage mechanism the established settings;
- (g) take measurements and record readings of all Terminals, Sub-branches, Branches and system after air balancing. Use the same set of measuring devices preferably and complete the work in a continuous manner;
- (h) finally, set the adjustable louvers, diffuser and cones to desired positions.

4.6 Tolerances in measurement

the Table V5 provides the recommended tolerance limits of measured airflow:

System type	Performance effect	Terminal	Branch	Total air flow
Mechanical ventilation, Comfort cooling	Low	+20% of design value	+10% of design value	+10% of design value
Process air conditioning, Escape route pressurisation	Medium	+15% of design value	+8% of design value	+10% of design value
Close control air conditioning	High	+10% of design value	+5% of design value	+5% of design value
<p><u>Notes:</u> Where the supply flow tends towards a tolerance limit, the associated extract flow should be regulated towards the same limit. Tolerances shown for Terminal are those accumulated during Terminal and Sub-branch regulation.</p>				

Table V5 - Recommended Tolerances Limits of Measured Airflow